

## » Das Linear System

Deutsch  
1/2015

 **MayTec**<sup>®</sup>

Eco-Slide komplett	4.001
--------------------	-------

Linear-Einheiten komplett	4.101
---------------------------	-------

Linear-Wellenführung komplett	4.119
-------------------------------	-------

Katalog in Vorbereitung:

Schlitten-Einheit	4.121
-------------------	-------

Antriebs-Einheit	4.131
------------------	-------

Umlenk-Einheit ohne Wellenabgang	4.141
----------------------------------	-------

Umlenk-Einheit mit Wellenabgang	4.151
---------------------------------	-------

Motor-Flansch	4.161
---------------	-------

Synchronisations-Antrieb	4.171
--------------------------	-------

Getriebe	4.181
----------	-------

Artikelnummer-Gruppe	Seite
4.000	Das MayTec Linear System..... 2
<b>4.000</b>	<b>Eco-Slide..... 3</b>
4.000	Artikel-Nummernschlüssel (Eco-Slide)..... 3
4.001	Eco-Slide komplett, mit Zahnriemen-Antrieb mit Gleitführung ..... 4
4.001	Auswahltabelle für Eco-Slide komplett..... 6
<b>4.100</b>	<b>Linear-Einheiten..... 7</b>
4.100	Artikel-Nummernschlüssel (Linear-Einheit) ..... 7
4.101	Linear-Einheiten komplett, mit Zahnriemen-Antrieb
4.101	mit Rollen ..... 8
4.101	mit Buchsen..... 10
4.101	Linear-System-Aufbau ..... 12
4.101	Auswahltabellen für Linear-Einheiten ..... 16
4.101	Wellenführung horizontal ..... 16
4.101	Wellenführung vertikal ..... 22
<b>4.119</b>	<b>Linear-Wellenführung komplett ..... 24</b>
4.119	Bauformen..... 24
4.119	Nummernschlüssel..... 25
4.119	Linear-Wellenführung, einseitig..... 26
4.119	Linear-Wellenführung, zweiseitig..... 35
4.119	Wellen-Führungsprofile ..... 42
4.119	für Wellen-Ø12 ..... 42
4.119	für Wellen-Ø16 ..... 43
4.119	für Wellen-Ø20 ..... 44
4.119	für Wellen-Ø25 ..... 45
4.119	Wellen ..... 46
4.119	mit Radialgewinde..... 47
4.119	Wellen-Bearbeitungen ..... 48
4.119	Bestell-Beispiel für Wellen..... 49

## Problemlösungen mit innovativem Profil.

### Das Linear System

Das MayTec Linear System ermöglicht die Verwendung aller Bauelemente der einschlägigen Lager-Hersteller zusammen mit dem MayTec Profil System.

Zusätzlich bietet MayTec ein umfangreiches Zubehör-Programm, das den Einsatz der Linearführungs-Technik in Verbindung mit der Profil-Technik erweitert und vereinfacht.

Das Baukasten-System ermöglicht die Kombination der verschiedenen Führungs-Systeme untereinander.

Wirtschaftliche und funktionelle Lösungen lassen sich einfach, sicher und schnell herstellen.

### Die Leistung

So vielseitig wie das MayTec Linear System ist der gesamte MayTec Leistungsumfang.

Sie können wählen:

- Lieferung der Grundelemente ab Werk
- Lieferung der zugeschnittenen und bearbeiteten Profile und Zusatzelemente nach Stückliste zur Selbstmontage
- Lieferung vormontierter Baugruppen
- Lieferung komplett montierter Anlagen
- Montage in Ihrem Haus

### Die Handhabung

Das MayTec Profilsystem ist besonders einfach zu bearbeiten, schnell zu montieren, flexibel und modular.

Außerdem ist es sehr leicht nach- bzw. umrüstbar und jederzeit wiederverwendbar.

Ein fachkundiges Team unterstützt Sie bei der Einführung des MayTec Systems und bei der Lösung Ihrer ganz individuellen Aufgabenstellung.

Die Auslegung erfolgt je nach benötigter Abmessung, Belastbarkeit und Stabilität.

### Gleit-Führung Eco-Slide

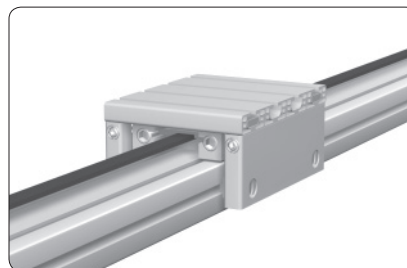

Gleitschlitten in variabler, einfacher und robuster Ausführung mit guter Gleiteigenschaft.

Breite und Höhe spielfrei einstellbar.

### Laufrollen-Führung

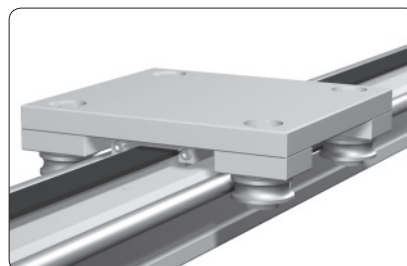

Ein seit langem erfolgreich eingesetztes Führungssystem mit vielseitigen Anwendungsmöglichkeiten.

Abhängig von der Aufgabenstellung können Laufrollen für niedrige oder hohe Belastung bzw. Genauigkeit eingesetzt werden.

- geeignet für rauhen und schmutzigen Einsatz
- hoch belastbar und verschleißfest
- hohe Präzision und geringe Reibung
- lange Lebensdauer

### Buchsen-Führung

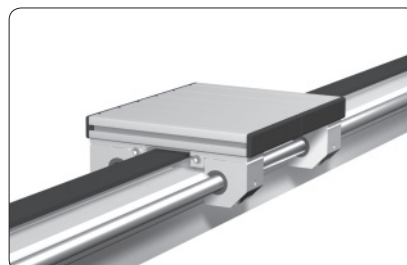

Ein bewährtes und durch seine kompakte Bauweise vielseitig einsetzbares Führungssystem.

Abhängig von der Aufgabenstellung können Gleit- oder Kugelbuchsen eingesetzt werden. Buchsen-Führungen werden dort eingesetzt, wo es auf hohe Positioniergenauigkeit und Wirkungsgrad ankommt.

- kompakte Bauweise
- niedrige Reibung
- hohe Steifigkeit
- hohe Genauigkeit
- große Laufruhe

**Fordern Sie uns !**

Eco-Slide komplett

4.0□□.□□□□□□.□□□□□.  
 4.0□□.□□□□□□.□□□□□.  
 4.0□□.□□□□□□.□□□□□.  
 4.0□□.□□□□□□.□□□□□.

**Schlüssel (Zeile 1)**

- Baugruppe <sup>1)</sup>
- Antrieb <sup>2)</sup>
- Profil
  - Abmessung
  - Lage <sup>3)</sup>

□□.□□□□.□□□  
 □□.□□□□.□□□  
 □□.□□□□.□□□  
 □□.□□□□.□□□  
 □□.□□□□.□□□  
 □□.□□□□.□□□  
 □□.□□□□.□□□  
 □□.□□□□.□□□  
 □□.□□□□.□□□

**Schlüssel (Zeile 2)**

- Schlitten
  - Grundplatte <sup>4)</sup>
  - Typ <sup>5)</sup>
- Riemen
  - Typ <sup>6)</sup>
  - Werkstoff <sup>7)</sup>
  - Breite
- Umlenk-Einheit
  - Motor <sup>8)</sup>
  - Wellenabgang - links <sup>9)</sup>
  - rechts <sup>9)</sup>

- <sup>1)</sup> 0 = Eco-Slide, komplett
- 1 = Linear-Führungsprofil
- 2 = Schlitten-Einheit
- 3 = Antriebs-Einheit
- 4 = Umlenk-Einheit ohne Wellenabgang
- 5 = Umlenk-Einheit mit Wellenabgang
- 6 = Motorflansch
- 7 = Synchronisations-Antrieb
- 8 = Getriebe
- <sup>2)</sup> 0 = ohne Antrieb
- 1 = Zahnriemen
- 2 = Kette
- 3 = Gewinde-Spindel
- 4 = Zahnstange
- 9 = Mehrfach

- <sup>3)</sup> H = horizontal
- N = neutral
- V = vertikal
- <sup>4)</sup> 1 = Alu-Platte
- 2 = Profil
- 3 = Profil-Rahmen
- <sup>5)</sup> 1 = ST-Verbinder
- 2 = Schraub-Verbinder
- <sup>6)</sup> A = HTD5M
- B = HTD8M
- <sup>7)</sup> G = Glasfaser
- S = Stahl

- <sup>8)</sup> 1 = für Motor mit Hohlwelle
- 2 = für Motor mit Welle
- 3 = für Motor mit Fuß
- <sup>9)</sup> 0 = ohne
- 1 = links
- 2 = rechts
- 3 = beidseitig

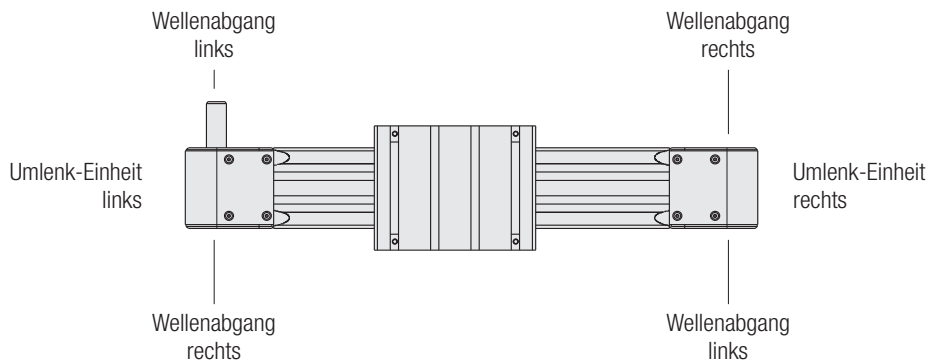

zusätzlich benötigte Bestellangaben:  
 • Hub

**Eco-Slide**

- mit Zahnriemen-Antrieb
- mit Gleitführung

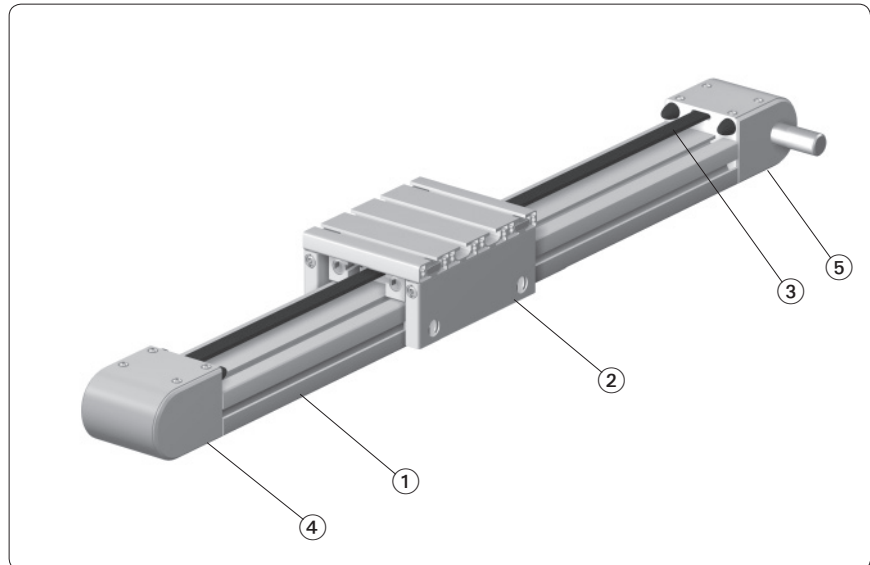

**Baugruppen für Eco-Slide**
**Bestell-Angaben:**

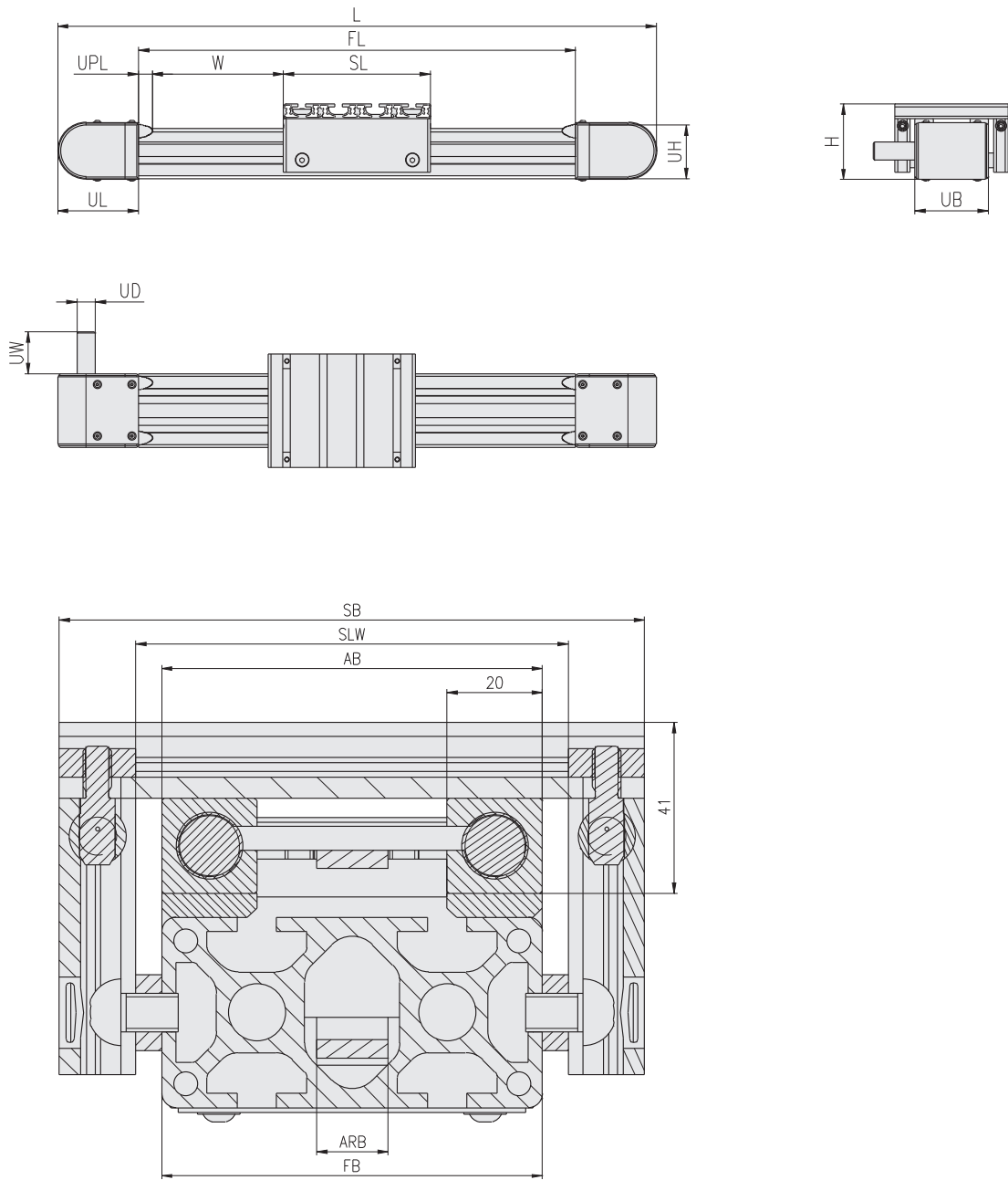
<b>Artikel-Nr.</b>	<b>Bezeichnung</b>	
4.001...	Eco-Slide komplett bestehend aus:	
① 4.019...	Linear-Führungsprofil	
② 4.021...	Schlitten-Einheit	<i>(Katalog in Vorbereitung)</i>
③ 4.031...	Antriebs-Einheit	<i>(Katalog in Vorbereitung)</i>
④ 4.041...	Umlenk-Einheit ohne Wellenabgang	<i>(Katalog in Vorbereitung)</i>
⑤ 4.051...	Umlenk-Einheit mit Wellenabgang	<i>(Katalog in Vorbereitung)</i>
⑥ 4.061...	Motor-Flansch	<i>(Katalog in Vorbereitung)</i>
⑦ 4.071...	Synchronisations-Antrieb	<i>(Katalog in Vorbereitung)</i>
⑧ 4.081...	Getriebe	<i>(Katalog in Vorbereitung)</i>

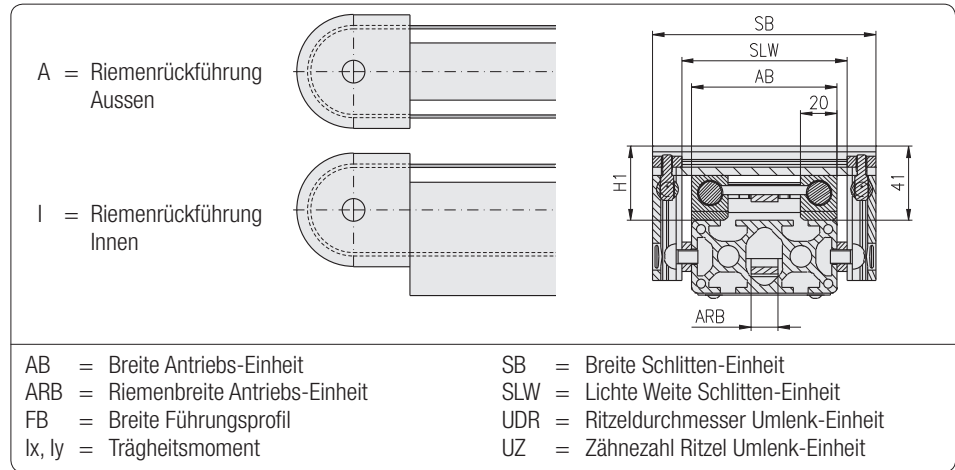

- AB = Breite Antriebs-Einheit
- ARB = Riemenbreite Antriebs-Einheit
- FB = Breite Führungsprofil
- FL = Länge Führungsprofil
- H = Gesamthöhe
- L = Gesamtlänge
- SB = Breite Schlitten-Einheit
- SL = Länge Schlitten-Einheit
- SLW = Lichte Weite Schlitten-Einheit
- UB = Breite Umlenk-Einheit
- UD = Durchmesser Wellenabgang Umlenk-Einheit
- UDR = Ritzeldurchmesser Umlenk-Einheit
- UH = Höhe Umlenk-Einheit
- UL = Länge Umlenk-Einheit
- UPL = Länge Parabelfeder Umlenk-Einheit
- UW = Länge Wellenabgang Umlenk-Einheit
- W = Hub

Eco-Slide komplett  
mit Zahnriemen-Antrieb

Eco-Slide, komplett		Linear-Führungsprofil			Umlenkeinheit						Schlitten-Einheit				
Bauform	Bestell-Nr.	Profil	Technische Daten		Typ	Riemen 5M15		Typ	Riemen 5M25		Rückführung ARB		SLW	AB	SB
		Maße	Ix	Iy		UZ	UDR		UZ	UDR	15	25			
	4.001.030060.65PH...	30×60	7	25	100	36	56,2	100	36	56,2	A	A	71	60	103
	4.001.030100.84PH...	30×100	12	115	100	36	56,2	100	36	56,2	A	A	111	100	143
	4.001.030150.85PH...	30×150	16	340	100	36	56,2	100	36	56,2	A	A	161	150	193
	4.001.040080.64PH...	40×80	24	82	60	28	43,4	100	40	62,5	I	A	91	80	123
	4.001.040120.84LH	40×120	26	194	100	40	62,5	100	40	62,5	A	A	131	120	163
	4.001.040160.104LH	40×160	37	478	60	28	43,4	100	40	62,5	I	A	171	160	203
	4.001.045090.64PH	45×90	34	126	60	28	43,4	100	44	68,9	I	A	101	90	133



Linear-Einheit komplett

4.1□□.□□□□□□.□□□□□□.	<b>Schlüssel (Zeile 1)</b>	
4.1□□.□□□□□□.□□□□□□.	Baugruppe <sup>1)</sup>	
4.1□□.□□□□□□.□□□□□□.	Antrieb <sup>2)</sup>	
4.1□□.□□□□□□ □□□□□□.	Profil	• Abmessung
4.1□□.□□□□□□.□□□□□□.		• Lage <sup>3)</sup>
4.1□□.□□□□□□.□□□□□□.	Wellen	• Lage <sup>4)</sup>
<hr/>		
□□.□□.□□□□□□□□□□	<b>Schlüssel (Zeile 2)</b>	
□□.□□.□□□□□□□□□□	Wellen	• Anzahl <sup>5)</sup>
□□.□□.□□□□□□□□□□		• Einbau <sup>6)</sup>
□□.□□.□□□□□□□□□□		• Ø
□□.□□.□□□□□□□□□□		• Material <sup>7)</sup>
□□.□□.□□□□□□□□□□	Schlitten	• Grundplatte <sup>8)</sup>
□□.□□.□□□□□□□□□□		• Lagerung
□□.□□.□□□□□□□□□□		- Rolle <sup>9)</sup>
□□.□□.□□□□□□□□□□		- Buchse <sup>10)</sup>
□□.□□.□□□□□□□□□□	Riemen	• Typ <sup>11)</sup>
□□.□□.□□□□□□□□□□		• Werkstoff <sup>12)</sup>
□□.□□.□□□□□□□□□□		• Breite
□□.□□.□□□□□□□□□□	Umlenk-Einheit	• Motor <sup>13)</sup>
□□.□□.□□□□□□□□□□		• Wellenabgang
□□.□□.□□□□□□□□□□		- links <sup>14)</sup>
□□.□□.□□□□□□□□□□		- rechts <sup>14)</sup>

- |   |  |   |
|---|--|---|
| <p><sup>1)</sup> 0 = Linear-Einheit komplett<br/>         1 = Linear-Führung<br/>         2 = Schlitten-Einheit<br/>         3 = Antriebs-Einheit<br/>         4 = Umlenk-Einheit ohne Wellenabgang<br/>         5 = Umlenk-Einheit mit Wellenabgang<br/>         6 = Motorflansch<br/>         7 = Synchronisations-Antrieb<br/>         8 = Getriebe</p> <p><sup>2)</sup> 0 = ohne Antrieb<br/>         1 = Zahnriemen<br/>         2 = Kette<br/>         3 = Gewinde-Spindel<br/>         4 = Zahnstange<br/>         9 = Mehrfach</p> <p><sup>3)</sup> H = horizontal<br/>         N = neutral<br/>         V = vertikal</p> | <p><sup>4)</sup> H = horizontal<br/>         V = vertikal</p> <p><sup>5)</sup> 1 = einseitig<br/>         2 = zweiseitig</p> <p><sup>6)</sup> 2 = mit Führungsprofil</p> <p><sup>7)</sup> Welle                      Befestigungsteile<br/>         1 = Vergütungsstahl      Stahl, verzinkt<br/>         2 = X46Cr13                  Stahl, verzinkt<br/>         3 = X46Cr13                  VA</p> <p><sup>8)</sup> 1 = Alu-Platte<br/>         2 = Profil<br/>         3 = Profil-Rahmen</p> <p><sup>9)</sup> 11 = 2×fest / 2×Exzenter von oben<br/>         12 = 2×fest / 2×Exzenter von unten<br/>         15 = 4×Exzenter von oben<br/>         16 = 4×Exzenter von unten</p> | <p><sup>10)</sup> 21 = Kugel<br/>         25 = Gleit; Kunststoff<br/>         28 = Gleit; Keramik</p> <p><sup>11)</sup> A = HTD5M<br/>         B = HTD8M</p> <p><sup>12)</sup> G = Glasfaser<br/>         S = Stahl</p> <p><sup>13)</sup> 1 = für Motor mit Hohlwelle<br/>         2 = für Motor mit Welle<br/>         3 = für Motor mit Fuß</p> <p><sup>14)</sup> 0 = ohne<br/>         1 = links<br/>         2 = rechts<br/>         3 = beidseitig</p> |
|---|--|---|

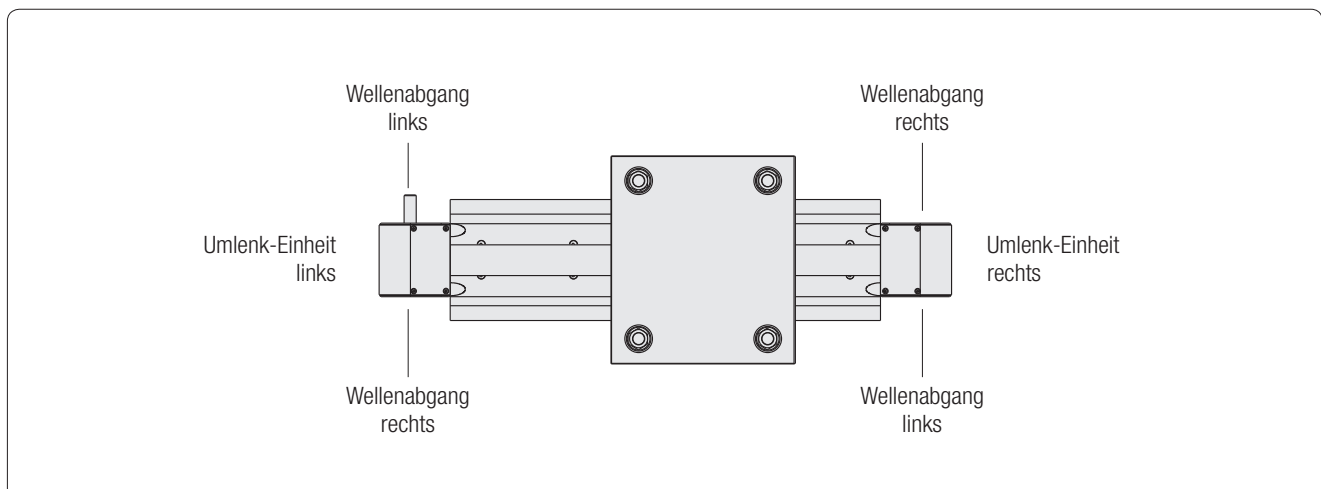

zusätzlich benötigte Bestellangaben:

- Hub
- Schlittenlänge

**Linear-Einheit**

- mit Zahnriemen-Antrieb
- mit Rollen

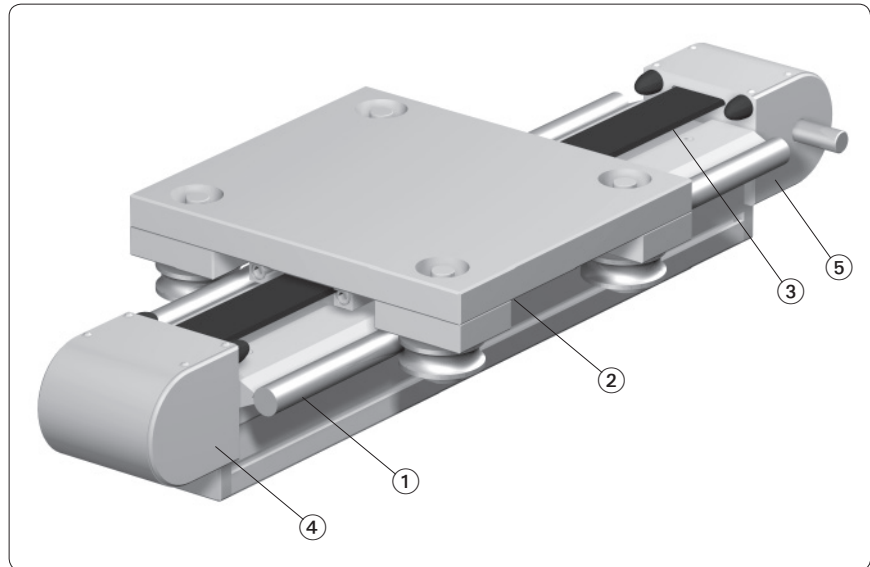
**Baugruppen für Linear-Einheiten**
**Bestell-Angaben:**

Artikel-Nr.	Bezeichnung	
4.101...	Linear-Einheit komplett	
	bestehend aus:	
① 4.119...	Linear-Wellen-Führung	
② 4.121...	Schlitten-Einheit	(Katalog in Vorbereitung)
③ 4.131...	Antriebs-Einheit	(Katalog in Vorbereitung)
④ 4.141...	Umlenk-Einheit ohne Wellenabgang	(Katalog in Vorbereitung)
⑤ 4.151...	Umlenk-Einheit mit Wellenabgang	(Katalog in Vorbereitung)
⑥ 4.161...	Motor-Flansch	(Katalog in Vorbereitung)
⑦ 4.171...	Synchronisations-Antrieb	(Katalog in Vorbereitung)
⑧ 4.181...	Getriebe	(Katalog in Vorbereitung)

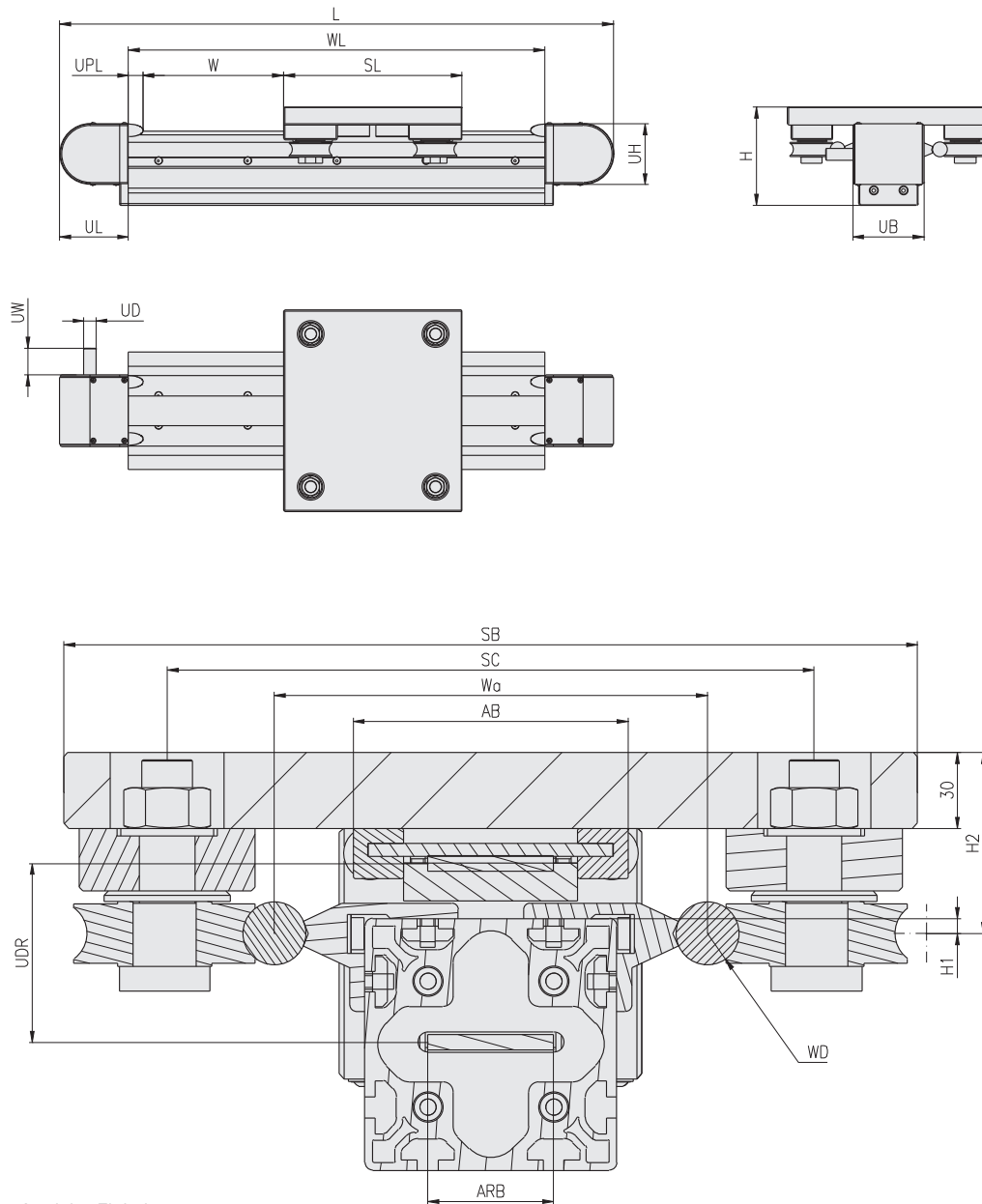

- AB = Breite Antriebs-Einheit
- ARB = Riemenbreite Antriebs-Einheit
- H = Gesamthöhe
- H1 = Höhe Wellenmitte zu Profiloberkante
- H2 = Höhe Wellenmitte zu Schlittenoberkante
- L = Gesamtlänge
- SB = Breite Schlitten-Einheit
- SC = Mittenabstand Laufrollen Schlitten-Einheit
- SL = Länge Schlitten-Einheit
- UB = Breite Umlenk-Einheit
- UD = Durchmesser Wellenabgang Umlenk-Einheit
- UDR = Ritzeldurchmesser Umlenk-Einheit
- UH = Höhe Umlenk-Einheit
- UL = Länge Umlenk-Einheit
- UPL = Länge Parabelfeder Umlenk-Einheit
- UW = Länge Wellenabgang Umlenk-Einheit
- W = Hub
- Wa = Achsabstand Wellen-Führung
- WD = Durchmesser Wellen-Führung
- WL = Profillänge Wellen-Führung

**Linear-Einheit**

- mit Zahnriemen-Antrieb
- mit Buchsen

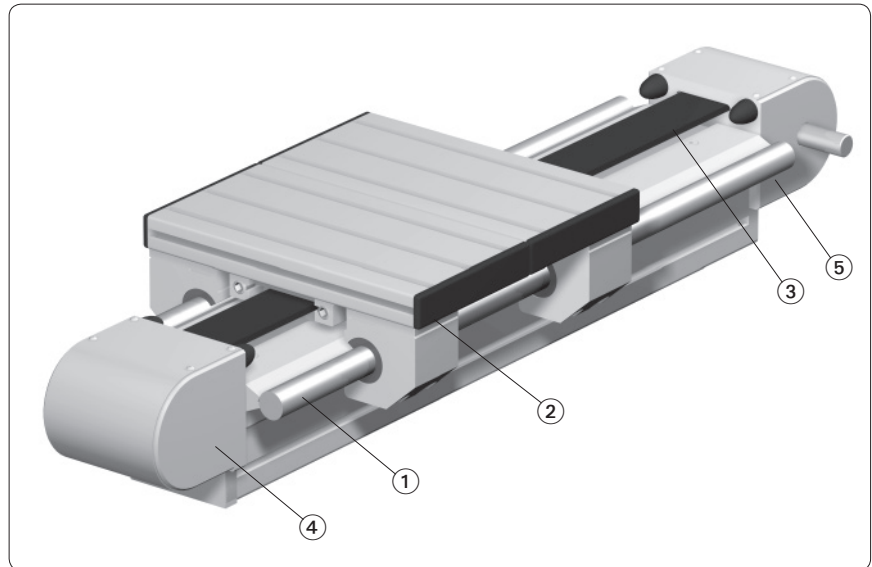
**Baugruppen für Linear-Einheiten**
**Bestell-Angaben:**

Artikel-Nr.	Bezeichnung	
4.101...	Linear-Einheit komplett	
	bestehend aus:	
① 4.119...	Linear-Wellen-Führung	
② 4.121...	Schlitten-Einheit	(Katalog in Vorbereitung)
③ 4.131...	Antriebs-Einheit	(Katalog in Vorbereitung)
④ 4.141...	Umlenk-Einheit ohne Wellenabgang	(Katalog in Vorbereitung)
⑤ 4.151...	Umlenk-Einheit mit Wellenabgang	(Katalog in Vorbereitung)
⑥ 4.161...	Motor-Flansch	(Katalog in Vorbereitung)
⑦ 4.171...	Synchronisations-Antrieb	(Katalog in Vorbereitung)
⑧ 4.181...	Getriebe	(Katalog in Vorbereitung)

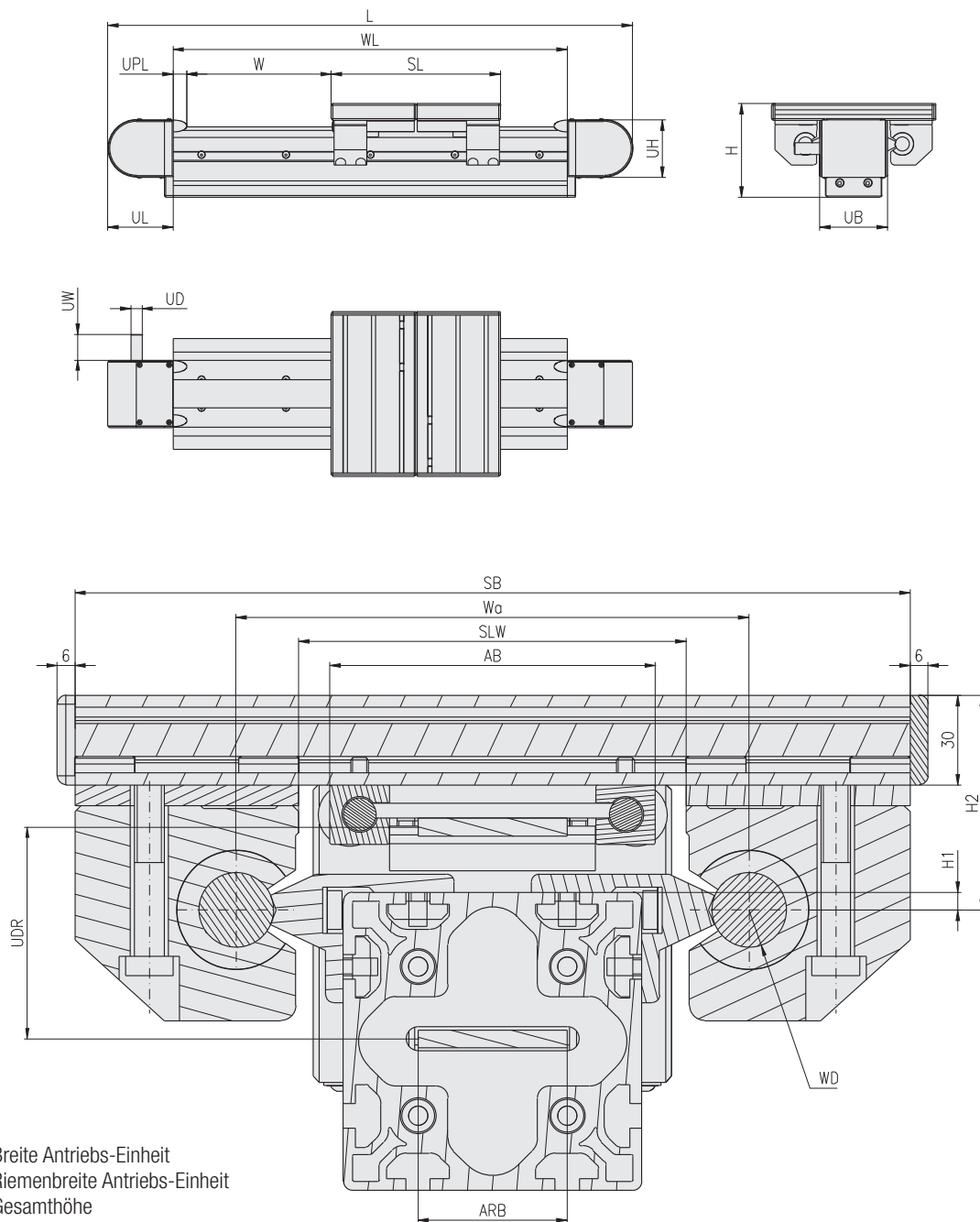

- AB = Breite Antriebs-Einheit
- ARB = Riemenbreite Antriebs-Einheit
- H = Gesamthöhe
- H1 = Höhe Wellenmitte zu Profilloberkante
- H2 = Höhe Wellenmitte zu Schlittenoberkante
- L = Gesamtlänge
- SB = Breite Schlitten-Einheit
- SC = Mittenabstand Laufrollen Schlitten-Einheit
- SL = Länge Schlitten-Einheit
- SLW = Lichte Weite Schlitten-Einheit
- UB = Breite Umlenk-Einheit
- UD = Durchmesser Wellenabgang Umlenk-Einheit
- UDR = Ritzeldurchmesser Umlenk-Einheit
- UH = Höhe Umlenk-Einheit
- UL = Länge Umlenk-Einheit
- UPL = Länge Parabelfeder Umlenk-Einheit
- UW = Länge Wellenabgang Umlenk-Einheit
- W = Hub
- Wa = Achsabstand Wellen-Führung
- WD = Durchmesser Wellen-Führung
- WL = Profillänge Wellen-Führung

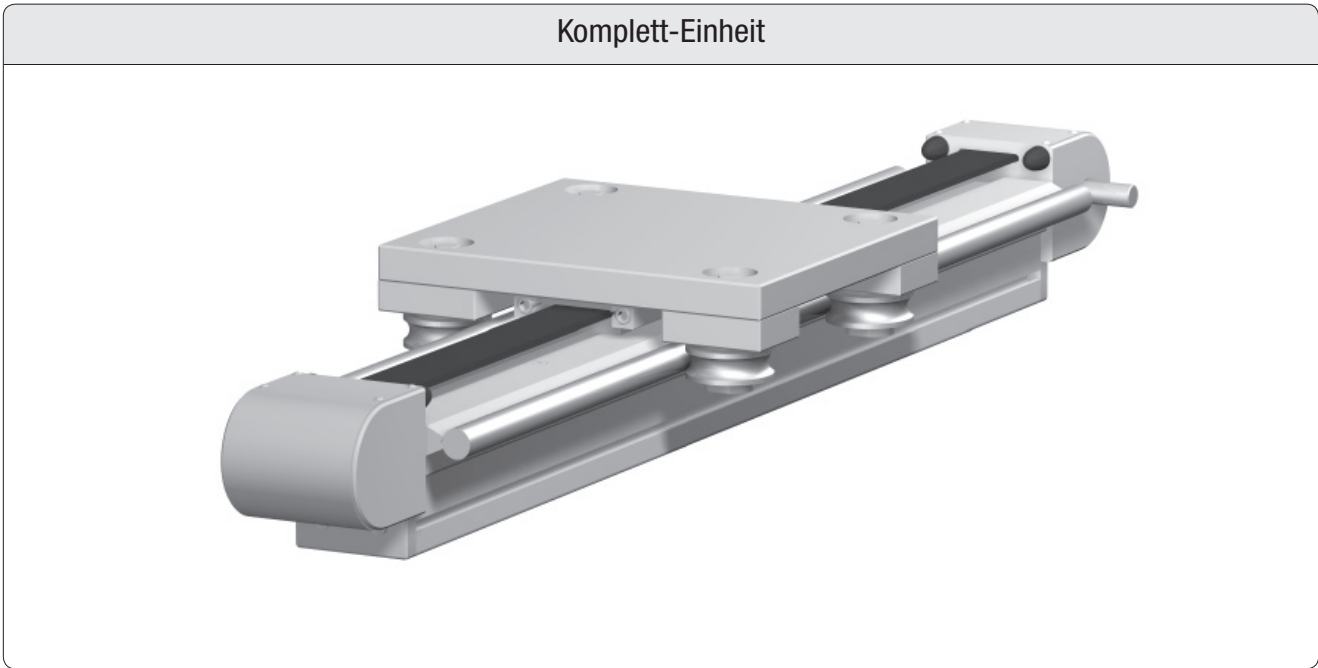

**Linear-Wellenführung**

**Einzelprofil-Ausführung**

**Rahmen-Ausführung**

horizontal

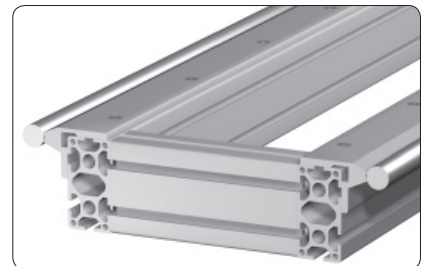
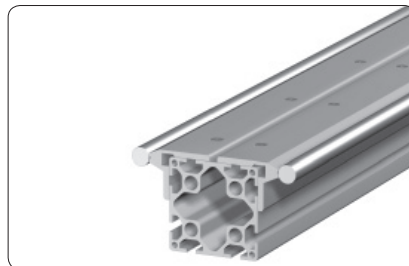

vertikal

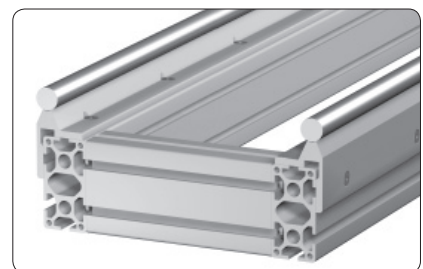
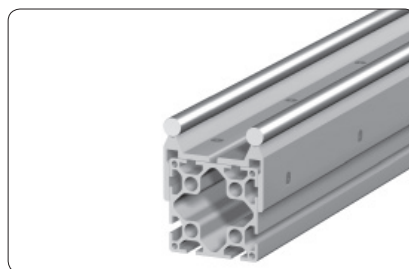

Wellen-Ø

12 mm	16 mm	20 mm	25 mm
-------	-------	-------	-------

Schlitten-Einheit

Buchsen-Führung

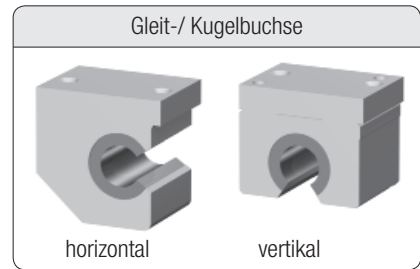
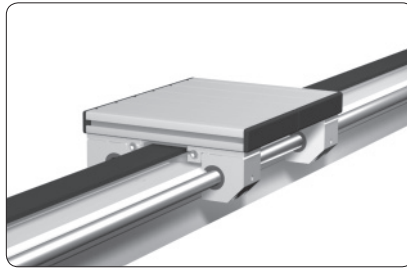

Laufrollen-Führung

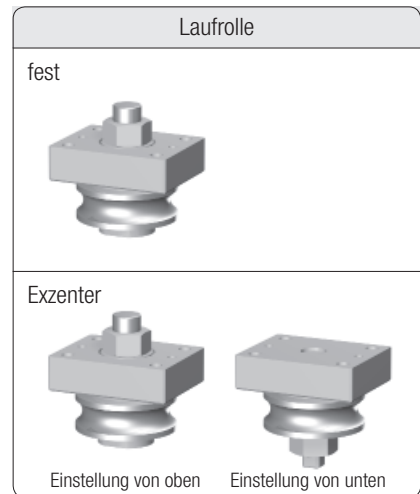
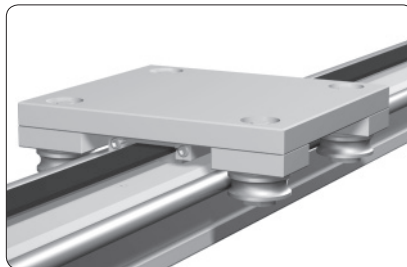

Schlittenplatten

Alu-Platte



Profil-Platte

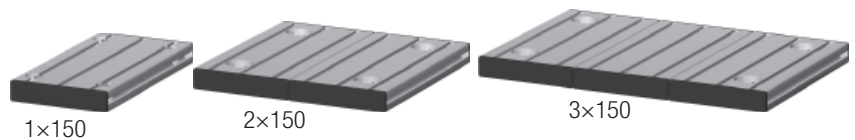

Profil-Rahmen

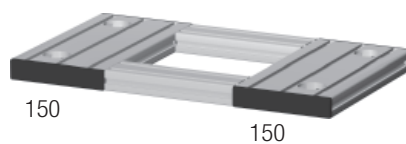

Antriebs-Einheit

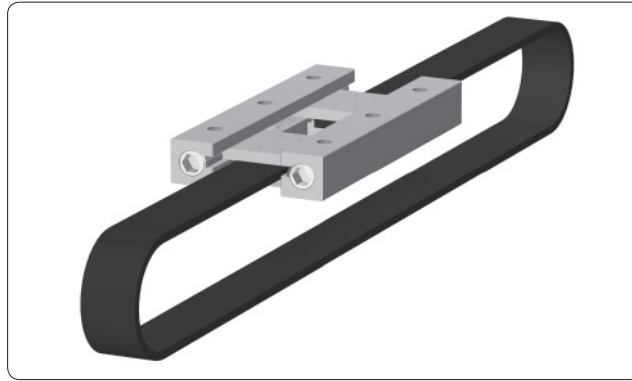

Zahnriemen		
-Typ:	5M	8M
-Breite:	15	20
	25	30
		50

Umlenk-Einheit

Wellenabgang



Wellenabgang

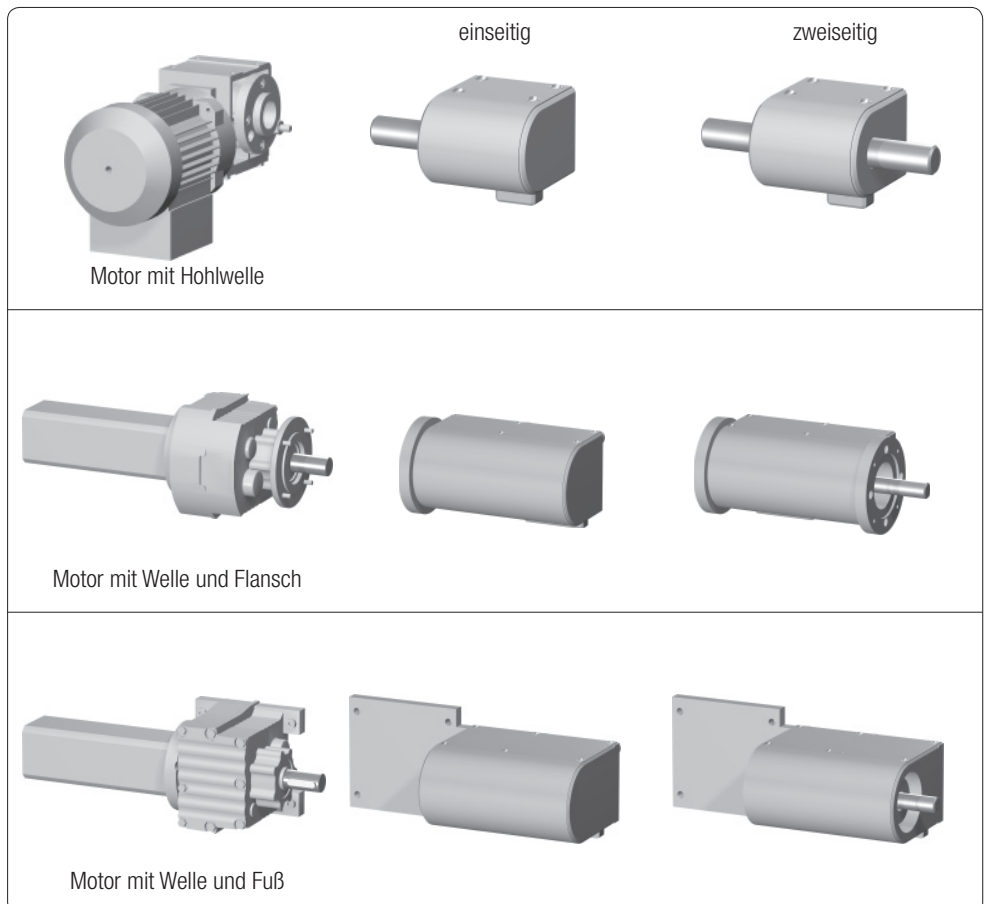





**Linear-Einheit komplett  
mit Zahnriemen-Antrieb**

 Wellenführung  
horizontal

A = Riemenrückführung Aussen

I = Riemenrückführung Innen

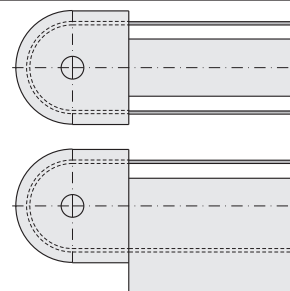

H1 = Höhe Wellenmitte zu Profiloberkante





lx, ly = Trägheitsmoment

UDR = Ritzeldurchmesser Umlenk-Einheit

UZ = Zähnezahlnzahl Ritzel Umlenk-Einh.

Wa = Achsabstand Wellen-Führung

WD = Durchmesser Wellen-Führung

Linear-Einheit komplett		Linear-Wellenführung						Umlenkeinheit					
Bauform	Bestell-Nr.	Profil Maße	Technische Daten					Typ	Riemen 5M		Typ	Riemen 8M	
			WD	Wa	H1	lx	ly		UZ	UDR		UZ	UDR
	4.101.030030.43NH22.12...	30x30	12	74	4	14	60	100	36	56,2	100		
	4.101.030030.43NH22.16...	30x30	16	82	3	16	104	100	36	56,2	100		
	4.101.040040.43NH22.12...	40x40	12	84	4	34	95	100	40	62,5	100	30	75,1
	4.101.040040.43NH22.16...	40x40	16	92	3	37	149	100	40	62,5	100	28	70,1
	4.101.040040.43NH22.20...	40x40	20	104	4	44	263	100	44	68,9	100	30	75,1
	4.101.040040.43NH22.25...	40x40	25	112	6	47	421	100	44	68,9	100	30	75,1
	4.101.045045.43NH22.12...	45x45	12	89	4	43	113	100	44	68,9	100	30	75,1
	4.101.045045.43NH22.16...	45x45	16	97	3	47	173	100	44	68,9	100	30	75,1
	4.101.045045.43NH22.20...	45x45	20	109	4	54	299	100	44	68,9	100	32	80,2
	4.101.045045.43NH22.25...	45x45	25	117	6	56	470	100	44	68,9	100	32	80,2
	4.101.050050.43NH22.12...	50x50	12	94	4	60	138	100	48	75,3	100	34	85,2
	4.101.050050.43NH22.16...	50x50	16	102	3	65	203	100	48	75,3	100	32	80,2
	4.101.050050.43NH22.20...	50x50	20	114	4	74	342	100	48	75,3	100	34	85,2
	4.101.050050.43NH22.25...	50x50	25	122	6	77	526	100	48	75,3	100	34	85,2
	4.101.060060.83LNH22.12...	60x60 L	12	104	4	76	182	100	36	56,2	100	22	54,7
	4.101.060060.83LNH22.16...	60x60 L	16	112	3	80	258	100	36	56,2	100	22	54,7
	4.101.080080.83NH22.12...	80x80	12	124	4	246	377	100	36	56,2	100	24	59,8
	4.101.080080.83NH22.16...	80x80	16	132	3	253	475	100	40	62,5	100	26	64,8
	4.101.080080.83NH22.20...	80x80	20	144	4	283	703	100	40	62,5	100	26	64,8
	4.101.080080.83NH22.25...	80x80	25	152	6	293	984	100	40	62,5	100	26	64,8
	4.101.090090.83LNH22.12...	90x90 L	12	134	4	294	455	100	40	62,5	100	26	64,8
	4.101.090090.83LNH22.16...	90x90 L	16	142	3	309	585	100	40	62,5	100	26	64,8
	4.101.090090.83LNH22.20...	90x90 L	20	154	4	335	829	100	44	68,9	100	28	70,1
	4.101.090090.83LNH22.25...	90x90 L	25	162	6	346	1.148	100	44	68,9	100	28	70,1
	4.101.090090.83NH22.12...	90x90	12	134	4	408	547	150	72	113,5	150	48	120,9
	4.101.090090.83NH22.16...	90x90	16	142	3	430	677	150	72	113,5	150	48	120,9
	4.101.090090.83NH22.20...	90x90	20	154	4	468	921	150	72	113,5	150	48	120,9
	4.101.090090.83NH22.25...	90x90	25	162	6	488	1.240	150	72	113,5	150	48	120,9
	4.101.100100.83NH22.12...	100x100	12	144	4	558	717	100	44	68,9	100	28	70,1
	4.101.100100.83NH22.16...	100x100	16	152	3	583	850	100	44	68,9	100	28	70,1
	4.101.100100.83NH22.20...	100x100	20	164	4	635	1.143	100	48	75,3	100	30	75,1
	4.101.100100.83NH22.25...	100x100	25	172	6	661	1.501	100	48	75,3	100	30	75,1
	4.101.030050.44HH22.12...	30x50	12	94	4	19	120	100	36	56,2	100	24	59,8
	4.101.030050.44HH22.16...	30x50	16	102	3	21	186	100	36	56,2	100	24	59,8
	4.101.030060.64HH22.12...	30x60	12	104	4	17	158	100	36	56,2	100	22	54,7
	4.101.030060.64HH22.16...	30x60	16	112	3	18	235	100	36	56,2	100	22	54,7
	4.101.030100.84HH22.12...	30x100	12	144	4	24	421	100	36	56,2	100	22	54,7
	4.101.030100.84HH22.16...	30x100	16	152	3	26	554	100	36	56,2	100	22	54,7
	4.101.030150.84HH22.12...	30x150	12	194	4	40	1.115	100	36	56,2	100	22	54,7
	4.101.030150.84HH22.16...	30x150	16	202	3	42	1.341	100	36	56,2	100	22	54,7
	4.101.040080.65HH22.12...	40x80	12	124	4	47	308	100	24	37,1	100	28	70,1
	4.101.040080.65HH22.16...	40x80	16	132	3	49	420	100	24	37,1	100	28	70,1
	4.101.040080.65HH22.20...	40x80	20	144	4	56	634	100	40	62,5	100	28	70,1
	4.101.040080.65HH22.25...	40x80	25	152	6	58	915	100	40	62,5	100	28	70,1

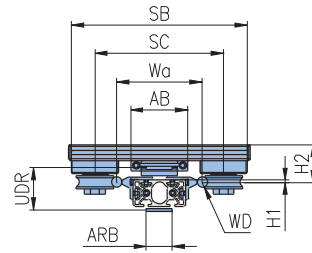
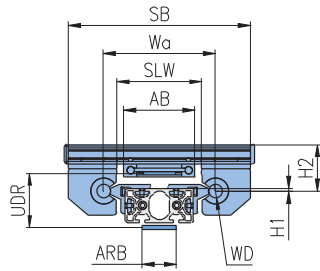



AB = Breite Antriebs-Einheit  
 ARB = Riemenbreite Antriebs-Einheit  
 H2 = Höhe Wellenmitte zu Schlittenoberkante

SB = Breite Schlitten-Einheit  
 SC = Mittenabstand Laufrollen Schlitten-Einheit  
 SLW = Lichte Weite Schlitten-Einheit

Schlitten-Einheit																			
Buchsenführung										Laufrollenführung									
Rückführung										Rückführung									
5M		8M			SLW	AB	SB	ARB	H2	5M		8M			SC	AB	SB	ARB	H2
15	25	20	30	50						15	25	20	30	50					
A					52	72	134	15	65	A					117,5	72	168	15	65
										A					145	72	183	15	65
A					62	72	144	15	65	A	A				127,5	87	178	25	65
A					66	72	166	15	65	A	A				155	87	225	25	65
A					70	72	190	15	72	A	A	A	A		186	96	276	30	72
A					70	72	220	15	72	A	A	A	A		199	109	289	50	72
A					67	72	149	15	65	A	A				132,5	83	183	25	65
A					71	72	171	15	65	A	A	A	A		160	90	230	30	65
A					75	72	195	15	72	A	A	A	A		191	101	281	40	72
A					75	72	225	15	72	A	A	A	A		204	114	294	50	72
A					72	72	154	15	65	A	A	A	A		137,5	107	207	40	65
A					76	72	176	15	65	A	A	A	A		165	95	235	30	65
A		A			80	72	200	20	72	A	A	A	A	A	196	106	286	50	72
A		A			80	72	230	20	72	A	A	A	A	A	209	119	299	50	72
I	I				82	82	164	25	65	I	I	I	I		147,5	98	198	40	65
I	I				86	85	186	25	65	I	I	I	I		175	105	245	40	65
I	I	I	I	I	102	100	184	50	65	I	I	I	I	I	167,5	118	218	50	65
I	I	I	I	I	106	105	206	50	65	I	I	I	I	I	195	125	265	60	65
I	I	I	I	I	110	109	230	50	72	I	I	I	I	I	226	136	316	75	72
I	I	I	I	I	110	109	260	50	72	I	I	I	I	I	239	149	329	90	72
I	I	I	I	I	112	110	194	50	65	I	I	I	I	I	177,5	128	228	70	65
I	I	I	I	I	116	115	216	50	65	I	I	I	I	I	205	135	275	75	65
I	I	I	I	I	120	115	240	60	72	I	I	I	I	I	236	146	326	85	72
I	I	I	I	I	120	115	270	60	72	I	I	I	I	I	249	159	339	100	72
A	A	A	A	A	112	110	194	50	65	A	A	A	A	A	177,5	128	228	70	65
A	A	A	A	A	116	115	216	50	65	A	A	A	A	A	205	135	275	75	65
A	A	A	A	A	120	115	240	60	72	A	A	A	A	A	236	146	326	85	72
A	A	A	A	A	120	115	270	60	72	A	A	A	A	A	249	159	339	100	72
I	I	I	I	I	122	120	204	60	65	I	I	I	I	I	187,5	138	238	75	65
I	I	I	I	I	126	125	226	65	65	I	I	I	I	I	215	145	285	85	65
I	I	I	I	I	130	125	250	70	72	I	I	I	I	I	246	156	336	95	72
I	I	I	I	I	130	125	280	70	72	I	I	I	I	I	259	169	349	110	72
A					72	72	154	15	65	A	A	A			137,5	88	188	25	65
A					76	72	176	15	65	A	A	A	A		165	95	235	30	65
A					82	82	164	25	65	A	A	A	A		147,5	98	198	40	65
A					86	82	186	25	65	A	A	A	A		175	105	245	45	65
A	A	A	A	A	122	120	204	60	65	A	A	A	A	A	187,5	138	238	75	65
A	A	A	A	A	126	125	226	65	65	A	A	A	A	A	215	145	285	85	65
A	A	A	A	A	172	170	254	110	65	A	A	A	A	A	237,5	188	288	130	65
A	A	A	A	A	176	175	276	115	65	A	A	A	A	A	265	195	335	135	65
I		A	A		102	100	184	40	65	I		A	A	A	167,5	118	218	60	65
I		A	A		106	105	206	45	65	I		A	A	A	195	125	265	65	65
A	A	A	A	A	110	105	230	50	72	A	A	A	A	A	226	136	316	75	72
A	A	A	A	A	110	105	260	50	72	A	A	A	A	A	239	149	329	90	72

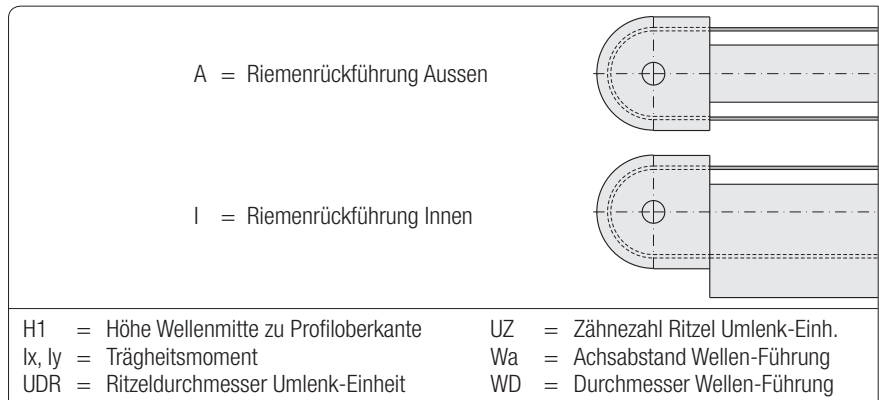
**Linear-Einheit komplett  
mit Zahnriemen-Antrieb**  
Wellenführung  
horizontal



Linear-Einheit komplett		Linear-Wellenführung						Umlenkeinheit					
Bauform	Bestell-Nr.	Profil Maße	Technische Daten					Typ	Riemen 5M		Typ	Riemen 8M	
			WD	Wa	H1	lx	ly		UZ	UDR		UZ	UDR
	4.101.040120.84LHH22.12...	40x120 L	12	164	4	49	659	100	44	68,9	100	28	70,1
	4.101.040120.84LHH22.16...	40x120 L	16	172	3	52	826	100	44	68,9	100	28	70,1
	4.101.040120.84LHH22.20...	40x120 L	20	184	4	59	1.199	100	44	68,9	100	28	70,1
	4.101.040120.84LHH22.25...	40x120 L	25	192	6	61	1.643	100	44	68,9	100	28	70,1
	4.101.040160.104LHH22.12...	40x160 L	12	204	4	62	1.263	60	24	37,1	100	28	70,1
	4.101.040160.104LHH22.16...	40x160 L	16	212	3	65	1.510	60	24	37,1	100	28	70,1
	4.101.040160.104LHH22.20...	40x160 L	20	224	4	73	207	60	24	37,1	100	28	70,1
	4.101.040160.104LHH22.25...	40x160 L	25	232	6	75	2.716	60	24	37,1	100	28	70,1
	4.101.045090.64HH22.12...	45x90	12	134	4	63	403	60	24	37,1	100	30	75,1
	4.101.045090.64HH22.16...	45x90	16	142	3	67	532	60	24	37,1	100	30	75,1
	4.101.045090.64HH22.20...	45x90	20	154	4	75	777	60	24	37,1	100	30	75,1
	4.101.045090.64HH22.25...	45x90	25	162	6	77	1.095	60	24	37,1	100	30	75,1
	4.101.050100.65HH22.12...	50x100	12	144	4	93	530	60	28	43,4	100	32	80,2
	4.101.050100.65HH22.16...	50x100	16	152	3	98	663	60	28	43,4	100	32	80,2
	4.101.050100.65HH22.20...	50x100	20	164	4	109	956	60	28	43,4	100	32	80,2
	4.101.050100.65HH22.25...	50x100	25	172	6	112	1.314	60	28	43,4	100	32	80,2
4.101.050150.65HH22.12...	50x150	12	194	4	122	1.313	100	48	75,3	100	32	80,2	
4.101.050150.85HH22.16...	50x150	16	202	3	129	1.539	100	48	75,3	100	32	80,2	
4.101.050150.85HH22.20...	50x150	20	214	4	141	2.052	100	48	75,3	100	32	80,2	
4.101.050150.85HH22.25...	50x150	25	222	6	144	2.640	100	48	75,3	100	32	80,2	
4.101.080160.124HH22.12...	80x160	12	204	4	380	1.688	60	44	68,9	150	44	110,7	
4.101.080160.124HH22.16...	80x160	16	212	3	397	1.936	60	44	68,9	150	44	110,7	
4.101.080160.124HH22.20...	80x160	20	224	4	430	2.500	100	60	94,4	150	44	110,7	
4.101.080160.124HH22.25...	80x160	25	232	6	446	3.142	100	60	94,4	150	44	110,7	
4.101.100200.124HH22.12...	100x200	12	244	4	953	3.717	100	60	94,4	150	56	141,2	
4.101.100200.124HH22.16...	100x200	16	252	3	985	4.060	100	60	94,4	150	56	141,2	
4.101.100200.124HH22.20...	100x200	20	264	4	1.055	4.858	150	60	94,4	150	56	141,2	
4.101.100200.124HH22.25...	100x200	25	272	6	1.096	5.733	150	72	113,5	150	56	141,2	
	4.101.030050.44VH22.12...	30x50	12	74	4	44	66	100	48	75,3			
	4.101.030050.44VH22.16...	30x50	16	82	3	48	109	100	48	75,3			
	4.101.030060.64VH22.12...	30x60	12	74	4	62	67	60	30	46,6			
	4.101.030060.64VH22.16...	30x60	16	82	3	67	110	60	30	46,6			
	4.101.030100.84VH22.12...	30x100	12	74	4	229	70	100	36	56,2	150	56	141,2
	4.101.030100.84VH22.16...	30x100	16	82	3	247	114	100	36	56,2	150	56	141,2
	4.101.040080.65VH22.12...	40x80	12	84	4	160	105	100	40	62,5	100	26	64,8
	4.101.040080.65VH22.16...	40x80	16	92	3	172	159	100	40	62,5	100	26	64,8
	4.101.040080.65VH22.20...	40x80	20	104	4	191	274	100	40	62,5	100	26	64,8
	4.101.040080.65VH22.25...	40x80	25	112	6	196	4.317	100	40	62,5	150	48	120,9
	4.101.040120.84LVH22.12...	40x120 L	12	84	4	374	108	100	40	62,5	100	26	64,8
	4.101.040120.84LVH22.16...	40x120 L	16	92	3	399	162	100	40	62,5	100	26	64,8
4.101.040120.84LVH22.20...	40x120 L	20	104	4	436	277	100	40	62,5	100	26	64,8	
4.101.040120.84LVH22.25...	40x120 L	25	112	6	450	434	100	40	62,5	100	26	64,8	

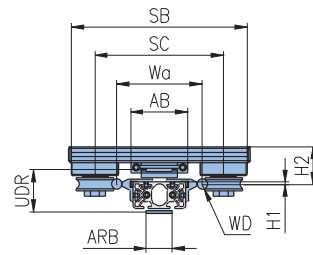
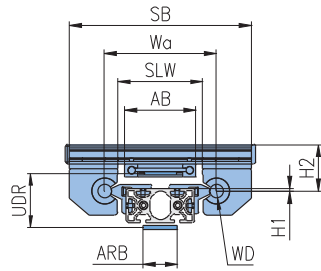



AB = Breite Antriebs-Einheit  
 ARB = Riemenbreite Antriebs-Einheit  
 H2 = Höhe Wellenmitte zu Schlittenoberkante

SB = Breite Schlitten-Einheit  
 SC = Mittenabstand Laufrollen Schlitten-Einheit  
 SLW = Lichte Weite Schlitten-Einheit

Schlitten-Einheit																			
Buchsenführung										Laufrollenführung									
Rückführung										Rückführung									
5M		8M			SLW	AB	SB	ARB	H2	5M		8M			SC	AB	SB	ARB	H2
15	25	20	30	50						15	25	20	30	50					
A	A	A	A	A	142	140	224	80	65	A	A	A	A	A	207,5	158	258	100	65
A	A	A	A	A	146	145	246	85	65	A	A	A	A	A	235	165	305	100	65
A	A	A	A	A	150	145	270	90	72	A	A	A	A	A	266	176	356	115	72
A	A	A	A	A	150	145	300	90	72	A	A	A	A	A	279	189	369	130	72
I	I	A	A	A	182	180	264	120	65	I		A	A	A	247,5	198	298	140	65
I	I	A	A	A	186	185	286	125	65	I		A	A	A	275	205	345	145	65
i	A	A	A	A	190	185	310	130	72	A	A	A	A	A	306	216	396	150	72
I	A	A	A	A	190	185	340	130	72	A	A	A	A	A	319	229	409	170	72
I		A	A	A	112	110	194	50	65	I		A	A	A	177,5	128	228	70	65
I		A	A	A	116	115	216	50	65	I		A	A	A	205	135	275	75	65
I	A	A	A	A	120	115	240	60	72	A	A	A	A	A	236	146	326	85	72
I	A	A	A	A	120	115	270	60	72	A	A	A	A	A	249	159	339	100	72
I	A	A	A	A	122	120	204	60	65	I	A	A	A	A	187,5	138	238	80	65
I	I	A	A	A	126	125	226	65	65	I	I	A	A	A	215	145	285	85	65
I	I	A	A	A	130	125	250	70	72	I	I	A	A	A	246	156	336	95	72
I	A	A	A	A	130	125	280	70	72	I	A	A	A	A	259	169	349	110	72
A	A	A	A	A	172	170	254	110	65	A	A	A	A	A	237,5	188	288	130	65
A	A	A	A	A	176	175	276	115	65	A	A	A	A	A	265	195	335	135	65
A	A	A	A	A	180	175	300	120	72	A	A	A	A	A	296	206	386	145	72
A	A	A	A	A	180	175	330	120	72	A	A	A	A	A	309	219	399	160	72
I		A	A	A	182	180	264	120	65	I		A	A	A	247,5	198	298	140	65
I		A	A	A	186	185	286	125	65	I		A	A	A	275	205	345	145	65
A	A	A	A	A	190	115	310	130	72	A	A	A	A	A	306	216	396	150	72
A	A	A	A	A	190	185	340	130	72	A	A	A	A	A	319	229	409	170	72
I	I	A	A	A	222	220	304	160	65	I	I	A	A	A	287,5	238	338	180	65
I	I	A	A	A	226	225	326	160	65	I	I	A	A	A	315	245	385	185	65
I	I	A	A	A	230	225	350	170	72	I	I	A	A	A	346	256	436	195	72
A	A	A	A	A	230	225	380	170	72	A	A	A	A	A	359	269	449	210	72
A					52	72	134	15	65	A					117,5	72	168	15	65
										A					145	72	183	15	65
I					52	72	134	15	65	I					117,5	72	168	15	65
										I					145	72	183	15	65
I					52	72	134	15	65	I					117,5	72	168	15	65
										I					145	72	183	15	65
I					62	72	144	15	65	I	I	I			127,5	87	187	25	65
I					66	72	166	15	65	I	I	I			155	87	225	25	65
I					70	72	190	15	72	I	I	I	I		186	96	276	30	72
I					70	72	220	15	72	I	I	I	I	A	199	109	289	50	72
I					62	72	144	15	65	I	I	I			127,5	87	187	25	65
I					66	72	166	15	65	I	I	I			155	87	225	25	65
I					70	72	190	15	72	I	I	I	I		186	96	276	30	72
I					70	72	220	15	72	I	I	I	I		199	109	289	50	72

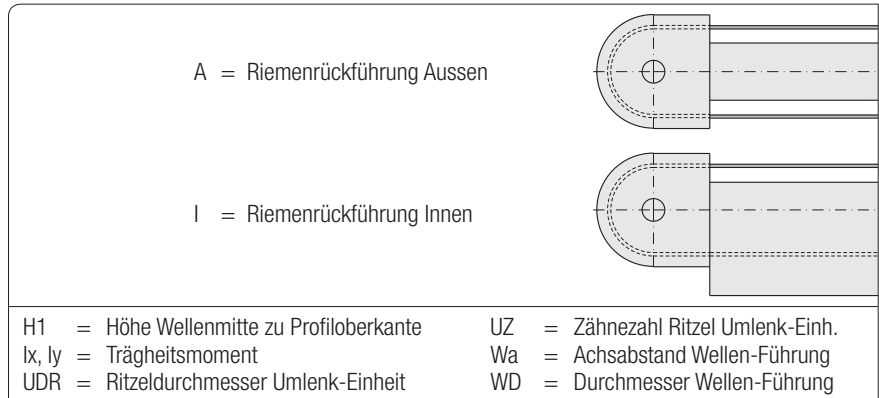
**Linear-Einheit komplett  
mit Zahnriemen-Antrieb**  
Wellenführung  
horizontal



Linear-Einheit komplett		Linear-Wellenführung						Umlenkeinheit					
Bauform	Bestell-Nr.	Profil Maße	Technische Daten					Typ	Riemen 5M		Typ	Riemen 8M	
			WD	Wa	H1	lx	ly		UZ	UDR		UZ	UDR
	4.101.040160.104LVH22.12...	40×160 L	12	84	4	857	118	100	40	62,5	100	26	64,8
	4.101.040160.104LVH22.16...	40×160 L	16	92	3	915	172	100	40	62,5	100	26	64,8
	4.101.040160.104LVH22.20...	40×160 L	20	104	4	1.010	287	100	40	62,5	100	26	64,8
	4.101.040160.104LVH22.25...	40×160 L	25	112	6	1.056	444	100	40	62,5	100	26	64,8
	4.101.045090.64VH22.12...	45×90	12	89	4	234	129	100	44	68,9	100	28	70,1
	4.101.045090.64VH22.16...	45×90	16	97	3	251	189	100	44	68,9	100	28	70,1
	4.101.045090.64VH22.20...	45×90	20	109	4	277	315	100	44	68,9	100	28	70,1
	4.101.045090.64VH22.25...	45×90	25	117	6	286	486	100	44	68,9	150	56	141,2
	4.101.050100.65VH22.12...	50×100	12	94	4	344	165	100	44	68,9	100	28	70,1
	4.101.050100.65VH22.16...	50×100	16	102	3	369	231	100	44	68,9	100	28	70,1
	4.101.050100.65VH22.20...	50×100	20	114	4	409	369	100	44	68,9	100	28	70,1
	4.101.050100.65VH22.25...	50×100	25	122	6	424	554	100	44	68,9	150	56	141,2
	4.101.050150.65VH22.12...	50×150	12	94	4	996	191	100	44	68,9	100	28	70,1
	4.101.050150.85VH22.16...	50×150	16	102	3	1.062	257	100	44	68,9	100	28	70,1
	4.101.050150.85VH22.20...	50×150	20	114	4	1.174	395	100	44	68,9	100	28	70,1
	4.101.050150.85VH22.25...	50×150	25	122	6	1.232	580	100	44	68,9	150	56	141,2
	4.101.080160.124VH22.12...	80×160	12	124	4	1.376	496	100	40	62,5	100	26	64,8
	4.101.080160.124VH22.16...	80×160	16	132	3	1.441	599	100	40	62,5	100	26	64,8
	4.101.080160.124VH22.20...	80×160	20	144	4	1.580	822	100	40	62,5	100	26	64,8
	4.101.080160.124VH22.25...	80×160	25	152	6	1.666	1.104	100	40	62,5	100	26	64,8
	4.101.100200.124VH22.12...	100×200	12	144	4	3.370	1.088	100	48	75,3	100	30	75,1
	4.101.100200.124VH22.16...	100×200	16	152	3	3.499	1.221	100	48	75,3	100	30	75,1
	4.101.100200.124VH22.20...	100×200	20	164	4	3.799	1.514	100	48	75,3	100	30	75,1
	4.101.100200.124VH22.25...	100×200	25	172	6	4.007	1.872	100	48	75,3	100	30	75,1

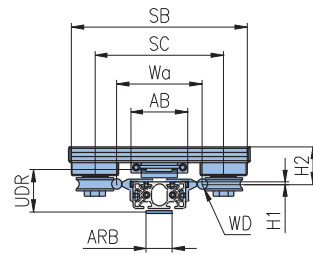
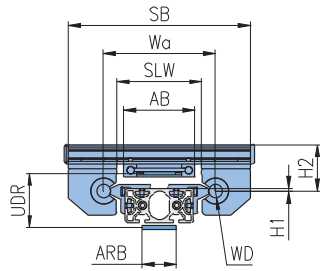

AB = Breite Antriebs-Einheit  
 ARB = Riemenbreite Antriebs-Einheit  
 H2 = Höhe Wellenmitte zu Schlittenoberkante

SB = Breite Schlitten-Einheit  
 SC = Mittenabstand Laufrollen Schlitten-Einheit  
 SLW = Lichte Weite Schlitten-Einheit

Schlitten-Einheit																			
Buchsenführung										Laufrollenführung									
Rückführung										Rückführung									
5M		8M			SLW	AB	SB	ARB	H2	5M		8M			SC	AB	SB	ARB	H2
15	25	20	30	50						15	25	20	30	50					
					62	72	144	15	65						127,5	87	187	25	65
					66	72	166	15	65						155	87	225	25	65
					70	72	190	15	72						186	96	276	30	72
					70	72	220	15	72						199	109	289	50	72
					67	72	149	15	65						132,5	83	183	25	65
					71	72	171	15	65						160	90	230	30	65
					75	72	195	15	72						191	101	281	40	72
					75	72	225	15	72					A	204	114	294	50	72
					72	72	154	15	65						137,5	88	188	25	65
					76	72	176	15	65						165	95	235	30	65
					80	72	200	15	72					A	196	106	286	50	72
					80	72	230	15	72					A	209	119	299	50	72
					72	72	154	15	65						137,5	88	188	25	65
					76	72	176	15	65						165	95	235	30	65
					80	82	200	25	72						196	106	286	50	72
					80	82	230	25	72						209	119	299	50	72
					102	100	184	30	65						167,5	118	218	50	65
					106	105	206	50	65						195	125	265	65	65
					110	105	230	50	72						226	136	316	75	72
					110	105	260	50	72						239	149	329	90	72
					122	120	204	60	65						187,5	138	238	75	65
					126	125	226	65	65						215	145	285	85	65
					130	125	250	70	72						246	156	336	95	72
					130	125	280	70	72						259	169	349	110	72

**Linear-Einheit komplett  
mit Zahnriemen-Antrieb**  
Wellenführung  
vertikal

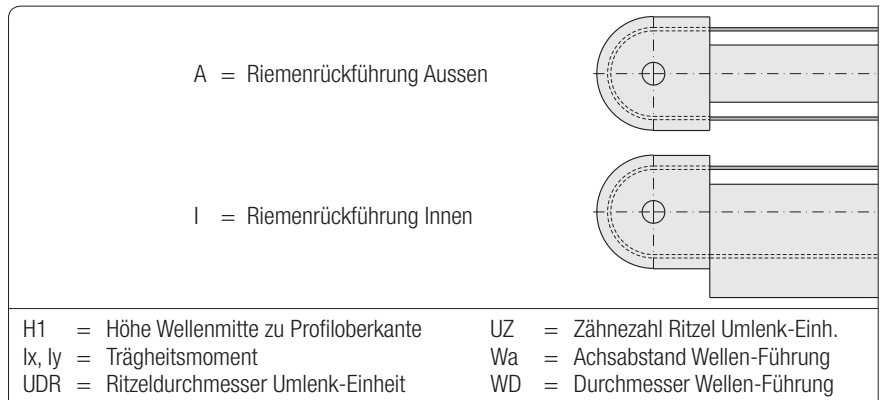

Linear-Einheit komplett		Linear-Wellenführung						Umlenkeinheit					
Bauform	Bestell-Nr.	Profil Maße	Technische Daten					Typ	Riemen 5M		Typ	Riemen 8M	
			WD	Wa	H1	lx	ly		UZ	UDR		UZ	UDR
	4.101.090090.83LNV22.12...	90×90 L	12	82	22	356	364	100	60	94,4	100	34	85,2
	4.101.090090.83LNV22.16...	90×90 L	16	84	26	424	405	100	60	94,4	150	38	95,4
	4.101.090090.83LNV22.20...	90×90 L	20	82	32	533	484	150	72	113,5	150	40	100,5
	4.101.090090.83LNV22.25...	90×90 L	25	78	36	659	542	150	72	113,5	150	44	110,7
	4.101.090090.83NV22.12...	90×90	12	82	22	480	456	100	60	94,4	150	56	141,2
	4.101.090090.83NV22.16...	90×90	16	84	26	565	496	100	60	94,4	150	64	161,6
	4.101.100100.83NV22.12...	100×100	12	92	22	637	617	100	60	94,4	150	38	95,4
	4.101.100100.83NV22.16...	100×100	16	94	26	727	661	100	60	94,4	100	36	90,3
	4.101.100100.83NV22.20...	100×100	20	92	32	897	767	150	72	113,5	150	44	110,7
	4.101.100100.83NV22.25...	100×100	25	88	36	1.087	842	150	72	113,5	150	48	120,9
	4.101.030100.84HV22.12...	30×100	12	92	22	50	321	100	60	94,4	100	32	80,2
	4.101.030100.84HV22.16...	30×100	16	94	26	75	37	100	60	94,4	100	36	90,3
	4.101.030150.84HV22.12...	30×150	12	142	22	71	971	100	60	94,4	100	32	80,2
	4.101.030150.84HV22.16...	30×150	16	144	26	102	1.072	100	60	94,4	100	36	90,3
	4.101.040120.84LHV22.12...	40×120 L	12	112	22	82	82	100	60	94,4	100	36	90,3
	4.101.040120.84LHV22.16...	40×120 L	16	114	26	113	606	100	60	94,4	150	38	95,4
	4.101.040120.84LHV22.20...	40×120 L	20	112	32	170	762	150	72	113,5	150	44	110,7
	4.101.040120.84LHV22.25...	40×120 L	25	108	36	237	879	150	72	113,5	150	48	120,9
	4.101.040160.104LHV22.12...	40×160 L	12	152	22	98	1.111	100	40	62,5	100	36	90,3
	4.101.040160.104LHV22.16...	40×160 L	16	154	26	133	1.225	100	44	68,9	150	40	100,5
	4.101.040160.104LHV22.20...	40×160 L	20	152	32	198	1.515	150	72	113,5	150	44	110,7
	4.101.040160.104LHV22.25...	40×160 L	25	148	36	277	1.742	150	72	113,5	150	48	120,9
	4.101.045090.64HV22.12...	45×90	12	82	22	100	312	100	44	68,9	150	38	95,4
	4.101.045090.64HV22.16...	45×90	16	84	26	135	347	100	48	75,3	150	44	110,7
	4.101.045090.64HV22.20...	45×90	20	82	32	200	431	150	72	113,5	150	44	110,7
	4.101.045090.64HV22.25...	45×90	25	78	36	276	489	150	72	113,5	150	48	120,9
	4.101.050100.65HV22.12...	50×100	12	92	22	135	430	100	40	62,5	150	40	100,5
	4.101.050100.65HV22.16...	50×100	16	94	26	176	474	100	44	68,9	150	44	110,7
	4.101.050100.65HV22.20...	50×100	20	92	32	252	580	100	48	75,3	100	32	80,2
	4.101.050100.65HV22.25...	50×100	25	88	36	341	655	150	72	113,5	150	56	141,2
	4.101.050150.85HV22.12...	50×150	12	142	22	167	1.170	150	72	113,5	150	40	100,5
	4.101.050150.85HV22.16...	50×150	16	144	26	213	1.270	150	72	113,5	150	44	110,7
	4.101.050150.85HV22.20...	50×150	20	142	32	298	1.523	150	72	113,5	150	48	120,9
	4.101.050150.85HV22.25...	50×150	25	138	36	400	1.719	150	72	113,5	150	56	141,2
	4.101.080160.124HV22.12...	80×160	12	152	22	446	1.536	100	40	62,5	150	56	141,2
	4.101.080160.124HV22.16...	80×160	16	154	26	519	1.651	100	44	68,9	150	56	141,2
4.101.080160.124HV22.20...	80×160	20	152	32	656	1.941	100	48	75,3		64	161,6	
4.101.080160.124HV22.25...	80×160	25	148	36	814	2.168					64	161,6	
4.101.100200.124HV22.12...	100×200	12	192	22	1.040	3.530	100	40	62,5		64	161,6	
4.101.100200.124HV22.16...	100×200	16	194	26	1.147	3.711	100	48	75,3		64	161,6	
4.101.100200.124HV22.20...	100×200	20	192	32	1.359	4.176	100	48	75,3		72	182,0	
4.101.100200.124HV22.25...	100×200	25	188	36	1.603	4.550	100	48	75,3		72	182,0	
	4.101.100200.124V22.12...	100×200	12	92	22	3.531	988	100	60	94,4	150	38	95,4
	4.101.100200.124V22.16...	100×200	16	94	26	3.792	1.032	100	60	94,4	100	36	90,3
	4.101.100200.124V22.20...	100×200	20	92	32	4.340	1.138	150	72	113,5	150	44	110,7
	4.101.100200.124V22.25...	100×200	25	88	36	4.901	1.213	150	72	113,5	150	48	120,9



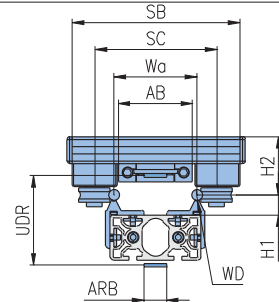
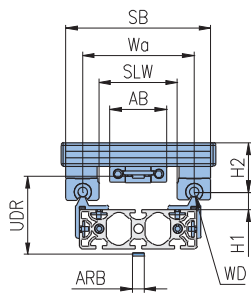

AB = Breite Antriebs-Einheit  
 ARB = Riemenbreite Antriebs-Einheit  
 H2 = Höhe Wellenmitte zu Schlittenoberkante

SB = Breite Schlitten-Einheit  
 SC = Mittenabstand Laufrollen Schlitten-Einheit  
 SLW = Lichte Weite Schlitten-Einheit

Schlitten-Einheit																			
Buchsenführung										Laufrollenführung									
Rückführung					SLW	AB	SB	ARB	H2	Rückführung					SC	AB	SB	ARB	H2
5M		8M								5M	8M								
15	25	20	30	50						15	25	20	30	50					
															125,5	76	176	15	65
															147	77	217	20	65
															164	74	254	15	72
															165	75	255	15	72
										A			A		125,5	76	176	15	65
													A		147	77	217	20	65
															135,5	86	186	25	65
															157	87	227	30	65
															174	84	264	25	72
															175	85	265	25	72
										A	A	A			135,5	86	186	25	65
										A	A	A	A		157	87	227	30	65
A	A	A	A		99	95	188	30	65	A	A	A	A	A	185,5	136	236	75	65
A	A	A	A		91	95	200	30	65	A	A	A	A	A	207	137	277	75	65
A					69	70	158	15	65	A	A	A	A	A	155,5	106	206	50	65
A					61	65	170	15	65	A	A	A	A	A	177	107	247	50	65
										A	A	A	A	A	194	104	284	45	72
										A	A	A	A	A	195	105	285	45	72
		A	A	A	109	105	198	50	65			A	A	A	195,5	146	246	85	65
		A	A		101	100	210	45	65			A	A	A	217	147	287	85	65
A	A	A	A		92	95	215	30	72	A	A	A	A	A	234	144	324	85	72
A					70	70	229	15	72	A	A	A	A	A	235	145	325	85	72
															125,5	76	176	15	65
												A			147	77	217	20	65
															164	74	254	15	72
															165	75	255	15	72
										A	A	A	A		135,5	86	186	25	65
												A	A		157	87	227	30	65
															174	84	264	25	72
										A	A	A			175	85	265	25	72
A	A	A	A		99	95	188	40	65	A	A	A	A	A	185,5	136	236	75	65
A	A	A	A		91	90	200	30	65	A	A	A	A	A	207	137	277	75	65
A	A	A			82	80	205	25	72	A	A	A	A	A	224	134	314	75	72
										A	A	A	A	A	225	135	315	75	72
		A	A	A	109	105	198	50	65			A	A	A	195,5	146	246	85	65
		A	A		101	100	210	45	65			A	A	A	217	147	287	85	65
	A	A	A		92	95	215	30	72			A	A	A	234	144	324	85	72
					70	70	229	15	72						235	145	325	85	72
		A	A	A	149	145	238	90	65			A	A	A	235,5	186	286	125	65
		A	A	A	141	140	250	85	65			A	A	A	257	187	327	130	65
		A	A	A	132	130	255	70	72			A	A	A	274	184	364	125	72
A	A	A	A	A	110	105	269	50	72	A	A	A	A	A	275	185	365	125	72
															135,5	86	186	25	65
															157	87	227	30	65
															174	84	264	25	72
															175	85	265	25	72

Bauformen

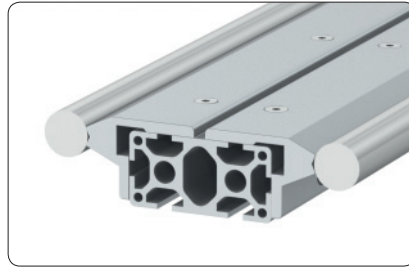

Lage

- N = neutral
- H = horizontal
- V = vertikal

NH  
(neutral, horizontal)

NV  
(neutral, vertikal)

HH  
(horizontal, horizontal)

HV  
(horizontal, vertikal)

VH  
(vertikal, horizontal)

VV  
(vertikal, vertikal)

Lage		Wellenführung	
Basis	Welle Profil	einseitig	zweiseitig
N	H	 1)	
N	V	 1)	
H	H	 2)	
H	V	 3)	
V	H	 3)	
V	V	 2)	

1), 2), 3): baugleich

## Linear-Wellenführung komplett

**4.119.00.□□□□□□. □□□□□□□□ □□□. □ / □□□□ Schlüssel**

 4.119.00.□□□□□□. □□□□□□□□ □□□. □ / □□□□ Profil
 

- Abmessung

 4.119.00.□□□□□□. □□□□□□□□ □□□. □ / □□□□
 

- Lage <sup>1)</sup>

 4.119.00.□□□□□□. □□□□□□□□ □□□. □ / □□□□ Wellen
 

- Lage <sup>2)</sup>

 4.119.00.□□□□□□. □□□□□□□□ □□□. □ / □□□□
 

- Anzahl <sup>3)</sup>

 4.119.00.□□□□□□. □□□□□□□□ □□□. □ / □□□□
 

- Einbau <sup>4)</sup>

 4.119.00.□□□□□□. □□□□□□□□ □□□. □ / □□□□
 

- Ø

 4.119.00.□□□□□□. □□□□□□□□ □□□. □ / □□□□
 

- Material <sup>5)</sup>

4.119.00.□□□□□□. □□□□□□□□ □□□. □ / □□□□ Länge

<sup>1)</sup> H = horizontal  
 N = neutral  
 V = vertikal

<sup>2)</sup> H = horizontal  
 V = vertikal

<sup>3)</sup> 1 = einseitig  
 2 = zweiseitig

<sup>4)</sup> 2 = mit Führungsprofil

<sup>5)</sup> Welle Befestigungsteile  
 1 = Vergütungsstahl Stahl, verzinkt  
 2 = X46Cr13 Stahl, verzinkt  
 3 = X46Cr13 VA

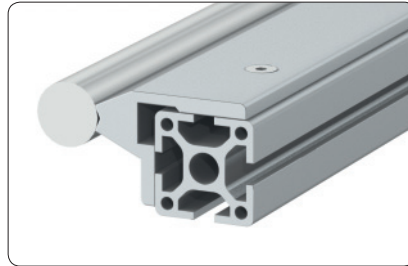
**LWF-1 komplett**  
 (Linear-Wellenführung, einseitig)

**Legende**

Bez. = Bezeichnung  
 L1 = Lage des Basisprofils  
 L2 = Lage des Führungsprofils  
 Ø = Wellendurchmesser in mm  
 a = Achsabstand in mm  
 I<sub>x</sub>, I<sub>y</sub> = Trägheitsmoment in cm<sup>4</sup>  
 G = Gewicht in kg/m

**Lage**

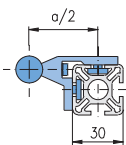
N = neutral  
 H = horizontal  
 V = vertikal



Bez.	Basisprofil Maße	Welle		Trägheitsm.			G kg/m	Bestell-Nr.
		L1	L2 Ø	a/2	I <sub>x</sub>	I <sub>y</sub>		
LWF-1	30×30	N	H 12	37	9	20	3,0	4.119.00.030030.43NH12.12...
LWF-1	30×30	N	H 16	41	9	31	3,7	4.119.00.030030.43NH12.16...

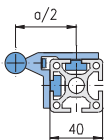

Bez.	Basisprofil Maße	Welle		Trägheitsm.			G kg/m	Bestell-Nr.
		L1	L2 Ø	a/2	I <sub>x</sub>	I <sub>y</sub>		
LWF-1	40×40	N	H 12	42	24	40	4,2	4.119.00.040040.43NH12.12...
LWF-1	40×40	N	H 16	46	25	56	4,9	4.119.00.040040.43NH12.16...
LWF-1	40×40	N	H 20	52	29	85	6,2	4.119.00.040040.43NH12.20...
LWF-1	40×40	N	H 25	56	30	119	7,8	4.119.00.040040.43NH12.25...

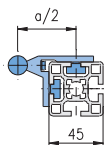

Bez.	Basisprofil Maße	Welle		Trägheitsm.			G kg/m	Bestell-Nr.
		L1	L2 Ø	a/2	I <sub>x</sub>	I <sub>y</sub>		
LWF-1	45×45	N	H 12	44,5	32	50	4,5	4.119.00.045045.43NH12.12...
LWF-1	45×45	N	H 16	48,5	34	68	5,2	4.119.00.045045.43NH12.16...
LWF-1	45×45	N	H 20	54,5	37	100	6,5	4.119.00.045045.43NH12.20...
LWF-1	45×45	N	H 25	58,5	39	138	8,1	4.119.00.045045.43NH12.25...

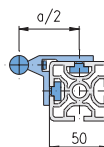

Bez.	Basisprofil Maße	Welle		Trägheitsm.			G kg/m	Bestell-Nr.
		L1	L2 Ø	a/2	I <sub>x</sub>	I <sub>y</sub>		
LWF-1	50×50	N	H 12	47	46	67	5,3	4.119.00.050050.43NH12.12...
LWF-1	50×50	N	H 16	51	49	88	6,0	4.119.00.050050.43NH12.16...
LWF-1	50×50	N	H 20	57	54	126	7,3	4.119.00.050050.43NH12.20...
LWF-1	50×50	N	H 25	61	56	172	8,9	4.119.00.050050.43NH12.25...

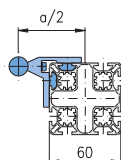

Bez.	Basisprofil Maße	Welle		Trägheitsm.			G kg/m	Bestell-Nr.
		L1	L2 Ø	a/2	I <sub>x</sub>	I <sub>y</sub>		
LWF-1	60×60 L	N	H 12	52	64	87	4,7	4.119.00.060060.83LNH12.12...
LWF-1	60×60 L	N	H 16	56	64	108	5,5	4.119.00.060060.83LNH12.16...

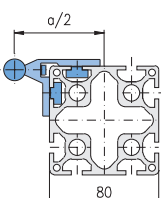

Bez.	Basisprofil Maße	Welle		Trägheitsm.			G kg/m	Bestell-Nr.
		L1	L2 Ø	a/2	I <sub>x</sub>	I <sub>y</sub>		
LWF-1	80×80	N	H 12	62	205	239	8,1	4.119.00.080080.83NH12.12...
LWF-1	80×80	N	H 16	66	209	272	8,8	4.119.00.080080.83NH12.16...
LWF-1	80×80	N	H 20	72	232	350	10,1	4.119.00.080080.83NH12.20...
LWF-1	80×80	N	H 25	76	241	435	11,7	4.119.00.080080.83NH12.25...

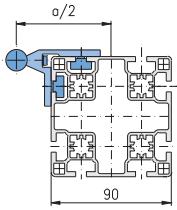

Bez.	Basisprofil Maße	Welle L1 L2 Ø	a/2	Trägheitsm. G			Bestell-Nr.
				lx	ly	kg/m	
LWF-1	90×90 L N	H 12	67	252	210	7,5	4.119.00.090090.83LNH12.12...
LWF-1	90×90 L N	H 16	71	280	350	8,2	4.119.00.090090.83LNH12.16...
LWF-1	90×90 L N	H 20	77	302	432	9,5	4.119.00.090090.83LNH12.20...
LWF-1	90×90 L N	H 25	81	316	524	11,1	4.119.00.090090.83LNH12.25...

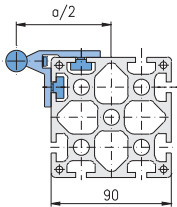

Bez.	Basisprofil Maße	Welle L1 L2 Ø	a/2	Trägheitsm. G			Bestell-Nr.
				lx	ly	kg/m	
LWF-1	90×90 N	H 12	67	346	386	11,7	4.119.00.090090.83NH12.12...
LWF-1	90×90 N	H 16	71	36	437	12,4	4.119.00.090090.83NH12.16...
LWF-1	90×90 N	H 20	77	386	527	13,7	4.119.00.090090.83NH12.20...
LWF-1	90×90 N	H 25	81	402	637	15,3	4.119.00.090090.83NH12.25...

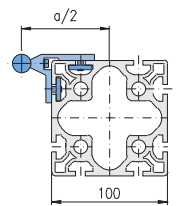

Bez.	Basisprofil Maße	Welle L1 L2 Ø	a/2	Trägheitsm. G			Bestell-Nr.
				lx	ly	kg/m	
LWF-1	100×100 N	H 12	72	479	523	11,9	4.119.00.100100.83NH12.12...
LWF-1	100×100 N	H 16	76	496	577	12,6	4.119.00.100100.83NH12.16...
LWF-1	100×100 N	H 20	82	531	684	13,9	4.119.00.100100.83NH12.20...
LWF-1	100×100 N	H 25	86	552	808	15,5	4.119.00.100100.83NH12.25...

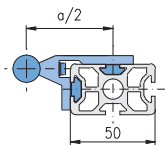

Bez.	Basisprofil Maße	Welle L1 L2 Ø	a/2	Trägheitsm. G			Bestell-Nr.
				lx	ly	kg/m	
LWF-1	30×50 H	H 12	47	13	51	4,1	4.119.00.030050.44HH12.12...
LWF-1	30×50 H	H 16	51	14	69	4,7	4.119.00.030050.44HH12.16...

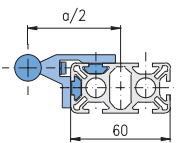

Bez.	Basisprofil Maße	Welle L1 L2 Ø	a/2	Trägheitsm. G			Bestell-Nr.
				lx	ly	kg/m	
LWF-1	30×60 H	H 12	52	13	68	4,2	4.119.00.030060.64HH12.12...
LWF-1	30×60 H	H 16	56	14	87	4,8	4.119.00.030060.64HH12.16...

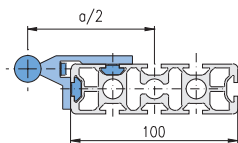

Bez.	Basisprofil Maße	Welle L1 L2 Ø	a/2	Trägheitsm. G			Bestell-Nr.
				lx	ly	kg/m	
LWF-1	30×100 H	H 12	72	19	220	5,5	4.119.00.030100.84HH12.12...
LWF-1	30×100 H	H 16	76	20	260	6,1	4.119.00.030100.84HH12.16...

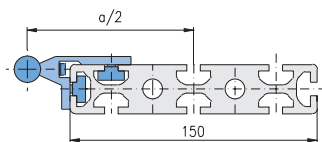

Bez.	Basisprofil Maße	Welle L1 L2 Ø	a/2	Trägheitsm. G			Bestell-Nr.
				lx	ly	kg/m	
LWF-1	30×150 H	H 12	97	33	733	10,0	4.119.00.030150.84HH12.12...
LWF-1	30×150 H	H 16	101	34	819	10,6	4.119.00.030150.84HH12.16...

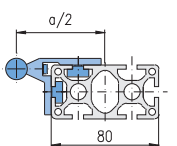

Bez.	Basisprofil Maße	Welle L1 L2 Ø	a/2	Trägheitsm. G			Bestell-Nr.
				lx	ly	kg/m	
LWF-1	40×80 H	H 12	62	36	160	6,0	4.119.00.040080.65HH12.12...
LWF-1	40×80 H	H 16	66	38	193	6,7	4.119.00.040080.65HH12.16...
LWF-1	40×80 H	H 20	72	42	252	8,0	4.119.00.040080.65HH12.20...
LWF-1	40×80 H	H 25	76	44	320	9,6	4.119.00.040080.65HH12.25...

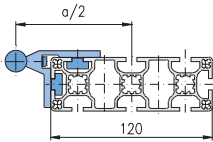

Bez.	Basisprofil Maße	Welle			Trägheitsm. G			Bestell-Nr.
		L1	L2	Ø	a/2	lx	ly	
LWF-1	40×120 L H	H	12	82	39	351	5,9	4.119.00.040120.84LHH12.12...
LWF-1	40×120 L H	H	16	86	41	400	6,6	4.119.00.040120.84LHH12.16...
LWF-1	40×120 L H	H	20	92	45	491	7,9	4.119.00.040120.84LHH12.20...
LWF-1	40×120 L H	H	25	96	46	589	9,5	4.119.00.040120.84LHH12.25...

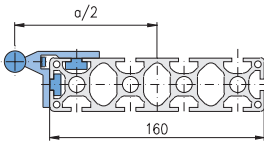

Bez.	Basisprofil Maße	Welle			Trägheitsm. G			Bestell-Nr.
		L1	L2	Ø	a/2	lx	ly	
LWF-1	40×160 L H	H	12	102	50	764	7,8	4.119.00.040160.104LHH12.12...
LWF-1	40×160 L H	H	16	106	52	846	8,5	4.119.00.040160.104LHH12.16...
LWF-1	40×160 L H	H	20	112	57	1.007	9,8	4.119.00.040160.104LHH12.20...
LWF-1	40×160 L H	H	25	116	58	1.174	11,4	4.119.00.040160.104LHH12.25...

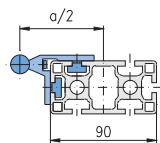

Bez.	Basisprofil Maße	Welle			Trägheitsm. G			Bestell-Nr.
		L1	L2	Ø	a/2	lx	ly	
LWF-1	45×90	H	12	67	50	226	6,6	4.119.00.045090.64HH12.12...
LWF-1	45×90	H	16	71	53	268	7,3	4.119.00.045090.64HH12.16...
LWF-1	45×90	H	20	77	58	337	8,6	4.119.00.045090.64HH12.20...
LWF-1	45×90	H	25	81	60	420	10,2	4.119.00.045090.64HH12.25...

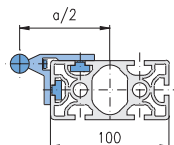

Bez.	Basisprofil Maße	Welle			Trägheitsm. G			Bestell-Nr.
		L1	L2	Ø	a/2	lx	ly	
LWF-1	50×100	H	12	72	76	324	8,1	4.119.00.050100.65HH12.12...
LWF-1	50×100	H	16	76	80	371	8,8	4.119.00.050100.65HH12.16...
LWF-1	50×100	H	20	82	87	462	10,1	4.119.00.050100.65HH12.20...
LWF-1	50×100	H	25	86	89	565	11,7	4.119.00.050100.65HH12.25...

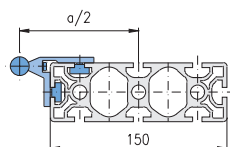

Bez.	Basisprofil Maße	Welle			Trägheitsm. G			Bestell-Nr.
		L1	L2	Ø	a/2	lx	ly	
LWF-1	50×150	H	12	97	103	894	10,3	4.119.00.050150.85HH12.12...
LWF-1	50×150	H	16	101	107	979	11,0	4.119.00.050150.85HH12.16...
LWF-1	50×150	H	20	107	115	1.151	12,3	4.119.00.050150.85HH12.20...
LWF-1	50×150	H	25	111	118	1.334	13,9	4.119.00.050150.85HH12.25...

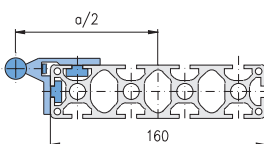

Bez.	Basisprofil Maße	Welle			Trägheitsm. G			Bestell-Nr.
		L1	L2	Ø	a/2	lx	ly	
LWF-1	80×160	H	12	102	330	1.227	12,7	4.119.00.080160.124HH12.12...
LWF-1	80×160	H	16	106	340	1.324	13,4	4.119.00.080160.124HH12.16...
LWF-1	80×160	H	20	112	362	1.527	14,7	4.119.00.080160.124HH12.20...
LWF-1	80×160	H	25	116	375	1.743	16,3	4.119.00.080160.124HH12.25...

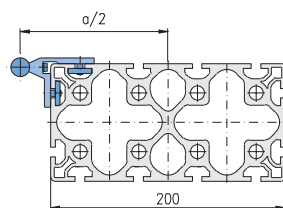

Bez.	Basisprofil Maße	Welle			Trägheitsm. G			Bestell-Nr.
		L1	L2	Ø	a/2	lx	ly	
LWF-1	100×200	H	12	122	858	3.044	19,7	4.119.00.100200.124HH12.12...
LWF-1	100×200	H	16	126	877	3.193	20,4	4.119.00.100200.124HH12.16...
LWF-1	100×200	H	20	132	919	3.519	21,7	4.119.00.100200.124HH12.20...
LWF-1	100×200	H	25	136	946	3.863	23,3	4.119.00.100200.124HH12.25...

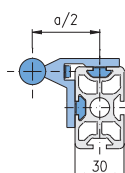

Bez.	Basisprofil Maße	Welle			Trägheitsm. G			Bestell-Nr.
		L1	L2	Ø	a/2	lx	ly	
LWF-1	30×50	V	12	37	32	26	4,1	4.119.00.030050.44VH12.12...
LWF-1	30×50	V	16	41	34	39	4,7	4.119.00.030050.44VH12.16...

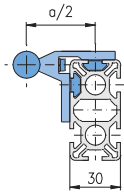

Bez.	Basisprofil Maße	Welle			Trägheitsm.			G kg/m	Bestell-Nr.
		L1	L2	Ø	a/2	I <sub>x</sub>	I <sub>y</sub>		
LWF-1	30×60	V	H	12	37	46	27	4,2	4.119.00.030060.64VH12.12...
LWF-1	30×60	V	H	16	41	49	40	4,8	4.119.00.030060.64VH12.16...

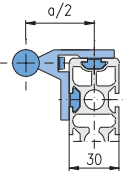

Bez.	Basisprofil Maße	Welle			Trägheitsm.			G kg/m	Bestell-Nr.
		L1	L2	Ø	a/2	I <sub>x</sub>	I <sub>y</sub>		
LWF-1	30×100	V	H	12	37	183	34	5,5	4.119.00.030100.84VH12.12...
LWF-1	30×100	V	H	16	41	193	49	6,1	4.119.00.030100.84VH12.16...

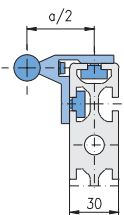

Bez.	Basisprofil Maße	Welle			Trägheitsm.			G kg/m	Bestell-Nr.
		L1	L2	Ø	a/2	I <sub>x</sub>	I <sub>y</sub>		
LWF-1	30×150	V	H	12	37	672	50	10,0	4.119.00.030150.84VH12.12...
LWF-1	30×150	V	H	16	41	707	68	10,6	4.119.00.030150.84VH12.16...

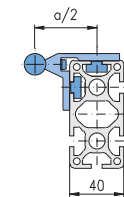

Bez.	Basisprofil Maße	Welle			Trägheitsm.			G kg/m	Bestell-Nr.
		L1	L2	Ø	a/2	I <sub>x</sub>	I <sub>y</sub>		
LWF-1	40×80	V	H	12	42	129	55	6,0	4.119.00.040080.65VH12.12...
LWF-1	40×80	V	H	16	46	136	74	6,7	4.119.00.040080.65VH12.16...
LWF-1	40×80	V	H	20	52	150	110	8,0	4.119.00.040080.65VH12.20...
LWF-1	40×80	V	H	25	56	156	153	9,6	4.119.00.040080.65VH12.25...

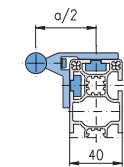

Bez.	Basisprofil Maße	Welle			Trägheitsm.			G kg/m	Bestell-Nr.
		L1	L2	Ø	a/2	I <sub>x</sub>	I <sub>y</sub>		
LWF-1	40×120 L	V	H	12	42	308	57	5,9	4.119.00.040120.84LVH12.12...
LWF-1	40×120 L	V	H	16	46	323	76	6,6	4.119.00.040120.84LVH12.16...
LWF-1	40×120 L	V	H	20	52	112	354	7,9	4.119.00.040120.84LVH12.20...
LWF-1	40×120 L	V	H	25	56	370	156	9,5	4.119.00.040120.84LVH12.25...

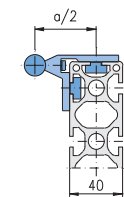

Bez.	Basisprofil Maße	Welle			Trägheitsm.			G kg/m	Bestell-Nr.
		L1	L2	Ø	a/2	I <sub>x</sub>	I <sub>y</sub>		
LWF-1	40×160 L	V	H	12	42	704	70	7,8	4.119.00.040160.104LVH12.12...
LWF-1	40×160 L	V	H	16	46	737	91	8,5	4.119.00.040160.104LVH12.16...
LWF-1	40×160 L	V	H	20	52	810	131	9,8	4.119.00.040160.104LVH12.20...
LWF-1	40×160 L	V	H	25	56	855	181	11,4	4.119.00.040160.104LVH12.25...

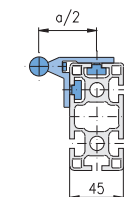

Bez.	Basisprofil Maße	Welle			Trägheitsm.			G kg/m	Bestell-Nr.
		L1	L2	Ø	a/2	I <sub>x</sub>	I <sub>y</sub>		
LWF-1	45×90	V	H	12	44,5	191	71	6,6	4.119.00.045090.64VH12.12...
LWF-1	45×90	V	H	16	48,5	200	92	7,3	4.119.00.045090.64VH12.16...
LWF-1	45×90	V	H	20	54,5	220	133	8,6	4.119.00.045090.64VH12.20...
LWF-1	45×90	V	H	25	58,5	229	183	10,2	4.119.00.045090.64VH12.25...

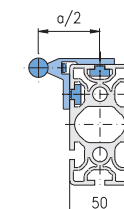

Bez.	Basisprofil Maße	Welle			Trägheitsm.			G kg/m	Bestell-Nr.
		L1	L2	Ø	a/2	I <sub>x</sub>	I <sub>y</sub>		
LWF-1	50×100	V	H	12	47	283	100	8,1	4.119.00.050100.65VH12.12...
LWF-1	50×100	V	H	16	51	297	124	8,8	4.119.00.050100.65VH12.16...
LWF-1	50×100	V	H	20	57	325	172	10,1	4.119.00.050100.65VH12.20...
LWF-1	50×100	V	H	25	61	340	230	11,7	4.119.00.050100.65VH12.25...

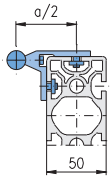

Bez.	Basisprofil Maße	Welle		a/2	Trägheitsm. G			Bestell-Nr.
		L1	L2 Ø		lx	ly	kg/m	
LWF-1	50×150 V	H	12	47	833	128	10,3	4.119.00.050150.85VH12.12...
LWF-1	50×150 V	H	16	51	868	154	11,0	4.119.00.050150.85VH12.16...
LWF-1	50×150 V	H	20	57	945	206	12,3	4.119.00.050150.85VH12.20...
LWF-1	50×150 V	H	25	61	995	271	13,9	4.119.00.050150.85VH12.25...

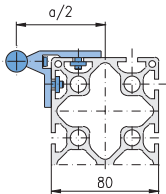

Bez.	Basisprofil Maße	Welle		a/2	Trägheitsm. G			Bestell-Nr.
		L1	L2 Ø		lx	ly	kg/m	
LWF-1	80×160 V	H	12	62	1.160	366	12,7	4.119.00.080160.124VH12.12...
LWF-1	80×160 V	H	16	66	1.202	409	13,4	4.119.00.080160.124VH12.16...
LWF-1	80×160 V	H	20	72	1.299	493	14,7	4.119.00.080160.124VH12.20...
LWF-1	80×160 V	H	25	76	1.365	594	16,3	4.119.00.080160.124VH12.25...

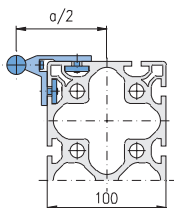

Bez.	Basisprofil Maße	Welle		a/2	Trägheitsm. G			Bestell-Nr.
		L1	L2 Ø		lx	ly	kg/m	
LWF-1	100×200 V	H	12	72	2.958	904	19,7	4.119.00.100200.124VH12.12...
LWF-1	100×200 V	H	16	76	3.034	964	20,4	4.119.00.100200.124VH12.16...
LWF-1	100×200 V	H	20	82	3.218	1.087	21,7	4.119.00.100200.124VH12.20...
LWF-1	100×200 V	H	25	86	3.355	1.232	23,3	4.119.00.100200.124VH12.25...

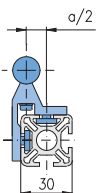

Bez.	Basisprofil Maße	Welle		a/2	Trägheitsm. G			Bestell-Nr.
		L1	L2 Ø		lx	ly	kg/m	
LWF-1	30×30 N	V	12	11	20	9	3,0	4.119.00.030030.43NV12.12...
LWF-1	30×30 N	V	16	12	31	9	3,7	4.119.00.030030.43NV12.16...

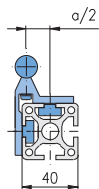

Bez.	Basisprofil Maße	Welle		a/2	Trägheitsm. G			Bestell-Nr.
		L1	L2 Ø		lx	ly	kg/m	
LWF-1	40×40 N	V	12	16	40	24	4,2	4.119.00.040040.43NV12.12...
LWF-1	40×40 N	V	16	17	56	25	4,9	4.119.00.040040.43NV12.16...
LWF-1	40×40 N	V	20	16	85	29	6,2	4.119.00.040040.43NV12.20...
LWF-1	40×40 N	V	25	14	119	30	7,8	4.119.00.040040.43NV12.25...

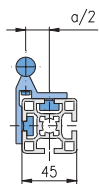

Bez.	Basisprofil Maße	Welle		a/2	Trägheitsm. G			Bestell-Nr.
		L1	L2 Ø		lx	ly	kg/m	
LWF-1	45×45 N	V	12	18,5	50	32	4,5	4.119.00.045045.43NV12.12...
LWF-1	45×45 N	V	16	19,5	68	34	5,2	4.119.00.045045.43NV12.16...
LWF-1	45×45 N	V	20	18,5	100	37	6,5	4.119.00.045045.43NV12.20...
LWF-1	45×45 N	V	25	16,5	138	39	8,1	4.119.00.045045.43NV12.25...

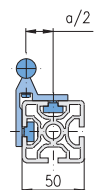

Bez.	Basisprofil Maße	Welle		a/2	Trägheitsm. G			Bestell-Nr.
		L1	L2 Ø		lx	ly	kg/m	
LWF-1	50×50 N	V	12	21	67	46	5,3	4.119.00.050050.43NV12.12...
LWF-1	50×50 N	V	16	22	88	49	6,0	4.119.00.050050.43NV12.16...
LWF-1	50×50 N	V	20	21	126	54	7,3	4.119.00.050050.43NV12.20...
LWF-1	50×50 N	V	25	19	172	56	8,9	4.119.00.050050.43NV12.25...

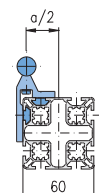

Bez.	Basisprofil Maße	Welle		a/2	Trägheitsm. G			Bestell-Nr.	
		L1	L2 Ø		lx	ly	kg/m		
LWF-1	60×60 L	N	V	12	26	87	64	4,7	4.119.00.060060.83LNV12.12...
LWF-1	60×60 L	N	V	16	27	108	64	5,5	4.119.00.060060.83LNV12.16...



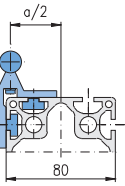

Bez.	Basisprofil Maße	Welle		Trägheitsm. lx ly	G kg/m	Bestell-Nr.
		L1	L2 Ø a/2			
LWF-1	80×80	N	V 12 36	239 205	8,1	4.119.00.080080.83NV12.12...
LWF-1	80×80	N	V 16 37	272 209	8,8	4.119.00.080080.83NV12.16...
LWF-1	80×80	N	V 20 36	350 232	10,1	4.119.00.080080.83NV12.20...
LWF-1	80×80	N	V 25 34	435 241	11,7	4.119.00.080080.83NV12.25...

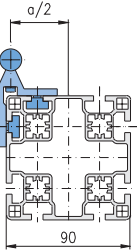

Bez.	Basisprofil Maße	Welle		Trägheitsm. lx ly	G kg/m	Bestell-Nr.
		L1	L2 Ø a/2			
LWF-1	90×90 L	N	V 12 41	290 252	7,5	4.119.00.090090.83LNV12.12...
LWF-1	90×90 L	N	V 16 41	350 280	8,2	4.119.00.090090.83LNV12.16...
LWF-1	90×90 L	N	V 20 41	432 302	9,5	4.119.00.090090.83LNV12.20...
LWF-1	90×90 L	N	V 25 39	524 316	11,1	4.119.00.090090.83LNV12.25...

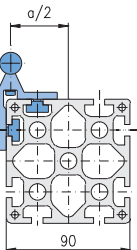

Bez.	Basisprofil Maße	Welle		Trägheitsm. lx ly	G kg/m	Bestell-Nr.
		L1	L2 Ø a/2			
LWF-1	90×90	N	V 12 41	386 346	11,7	4.119.00.090090.83NV12.12...
LWF-1	90×90	N	V 16 41	437 360	12,4	4.119.00.090090.83NV12.16...
LWF-1	90×90	N	V 20 41	527 386	13,7	4.119.00.090090.83NV12.20...
LWF-1	90×90	N	V 25 39	637 402	15,3	4.119.00.090090.83NV12.25...

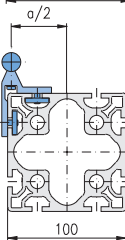

Bez.	Basisprofil Maße	Welle		Trägheitsm. lx ly	G kg/m	Bestell-Nr.
		L1	L2 Ø a/2			
LWF-1	100×100	N	V 12 46	523 479	11,9	4.119.00.100100.83NV12.12...
LWF-1	100×100	N	V 16 47	577 496	12,6	4.119.00.100100.83NV12.16...
LWF-1	100×100	N	V 20 46	684 531	13,9	4.119.00.100100.83NV12.20...
LWF-1	100×100	N	V 25 44	808 552	15,5	4.119.00.100100.83NV12.25...

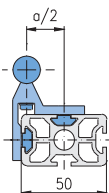

Bez.	Basisprofil Maße	Welle		Trägheitsm. lx ly	G kg/m	Bestell-Nr.
		L1	L2 Ø a/2			
LWF-1	30×50	H	V 12 21	26 32	4,1	4.119.00.030050.44HV12.12...
LWF-1	30×50	H	V 16 22	39 34	4,7	4.119.00.030050.44HV12.16...

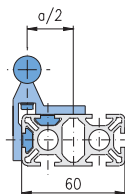

Bez.	Basisprofil Maße	Welle		Trägheitsm. lx ly	G kg/m	Bestell-Nr.
		L1	L2 Ø a/2			
LWF-1	30×60	H	V 12 26	27 46	4,2	4.119.00.030060.64HV12.12...
LWF-1	30×60	H	V 16 27	40 49	4,8	4.119.00.030060.64HV12.16...

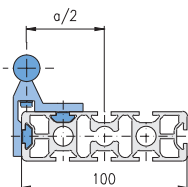

Bez.	Basisprofil Maße	Welle		Trägheitsm. lx ly	G kg/m	Bestell-Nr.
		L1	L2 Ø a/2			
LWF-1	30×100	H	V 12 46	34 183	5,5	4.119.00.030100.84HV12.12...
LWF-1	30×100	H	V 16 47	49 193	6,1	4.119.00.030100.84HV12.16...

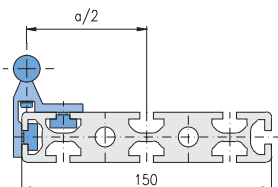

Bez.	Basisprofil Maße	Welle		Trägheitsm. lx ly	G kg/m	Bestell-Nr.
		L1	L2 Ø a/2			
LWF-1	30×150	H	V 12 71	50 672	10,0	4.119.00.030150.84HV12.12...
LWF-1	30×150	H	V 16 72	68 707	10,6	4.119.00.030150.84HV12.16...

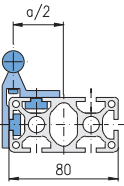

Bez.	Basisprofil Maße	Welle		Trägheitsm.			G kg/m	Bestell-Nr.
		L1	L2 Ø	a/2	lx	ly		
LWF-1	40×80	H	V 12	36	55	129	6,0	4.119.00.040080.65HV12.12...
LWF-1	40×80	H	V 16	37	74	136	6,7	4.119.00.040080.65HV12.16...
LWF-1	40×80	H	V 20	36	110	150	8,0	4.119.00.040080.65HV12.20...
LWF-1	40×80	H	V 25	34	153	156	9,6	4.119.00.040080.65HV12.25...

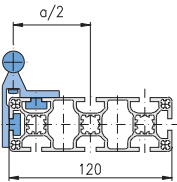

Bez.	Basisprofil Maße	Welle		Trägheitsm.			G kg/m	Bestell-Nr.
		L1	L2 Ø	a/2	lx	ly		
LWF-1	40×120 L	H	V 12	56	57	308	5,9	4.119.00.040120.84LHV12.12...
LWF-1	40×120 L	H	V 16	57	76	323	6,6	4.119.00.040120.84LHV12.16...
LWF-1	40×120 L	H	V 20	56	354	112	7,9	4.119.00.040120.84LHV12.20...
LWF-1	40×120 L	H	V 25	54	156	370	9,5	4.119.00.040120.84LHV12.25...

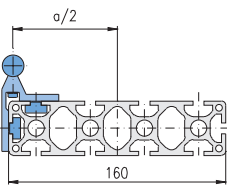

Bez.	Basisprofil Maße	Welle		Trägheitsm.			G kg/m	Bestell-Nr.
		L1	L2 Ø	a/2	lx	ly		
LWF-1	40×160 L	H	V 12	76	70	704	7,8	4.119.00.040160.104LHV12.12...
LWF-1	40×160 L	H	V 16	77	91	737	8,5	4.119.00.040160.104LHV12.16...
LWF-1	40×160 L	H	V 20	76	131	810	9,8	4.119.00.040160.104LHV12.20...
LWF-1	40×160 L	H	V 25	74	181	855	11,4	4.119.00.040160.104LHV12.25...

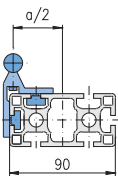

Bez.	Basisprofil Maße	Welle		Trägheitsm.			G kg/m	Bestell-Nr.
		L1	L2 Ø	a/2	lx	ly		
LWF-1	45×90	H	V 12	41	71	191	6,6	4.119.00.045090.64HV12.12...
LWF-1	45×90	H	V 16	42	92	200	7,3	4.119.00.045090.64HV12.16...
LWF-1	45×90	H	V 20	41	133	220	8,6	4.119.00.045090.64HV12.20...
LWF-1	45×90	H	V 25	39	183	229	10,2	4.119.00.045090.64HV12.25...

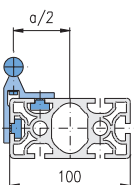

Bez.	Basisprofil Maße	Welle		Trägheitsm.			G kg/m	Bestell-Nr.
		L1	L2 Ø	a/2	lx	ly		
LWF-1	50×100	H	V 12	46	100	283	8,1	4.119.00.050100.65HV12.12...
LWF-1	50×100	H	V 16	47	124	297	8,8	4.119.00.050100.65HV12.16...
LWF-1	50×100	H	V 20	46	172	325	10,1	4.119.00.050100.65HV12.20...
LWF-1	50×100	H	V 25	44	230	340	11,7	4.119.00.050100.65HV12.25...

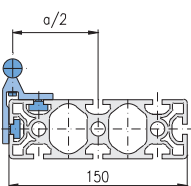

Bez.	Basisprofil Maße	Welle		Trägheitsm.			G kg/m	Bestell-Nr.
		L1	L2 Ø	a/2	lx	ly		
LWF-1	50×150	H	V 12	71	128	833	10,3	4.119.00.050150.85HV12.12...
LWF-1	50×150	H	V 16	72	154	868	11,0	4.119.00.050150.85HV12.16...
LWF-1	50×150	H	V 20	71	206	945	12,3	4.119.00.050150.85HV12.20...
LWF-1	50×150	H	V 25	69	271	995	13,9	4.119.00.050150.85HV12.25...

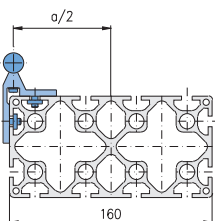

Bez.	Basisprofil Maße	Welle		Trägheitsm.			G kg/m	Bestell-Nr.
		L1	L2 Ø	a/2	lx	ly		
LWF-1	80×160	H	V 12	76	366	1.160	12,7	4.119.00.080160.124HV12.12...
LWF-1	80×160	H	V 16	77	409	1.202	13,4	4.119.00.080160.124HV12.16...
LWF-1	80×160	H	V 20	76	493	1.299	14,7	4.119.00.080160.124HV12.20...
LWF-1	80×160	H	V 25	74	594	1.365	16,3	4.119.00.080160.124HV12.25...

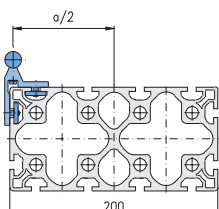

Bez.	Basisprofil Maße	Welle		Trägheitsm.			G kg/m	Bestell-Nr.
		L1	L2 Ø	a/2	lx	ly		
LWF-1	100×200	H	V 12	96	904	2.958	19,7	4.119.00.100200.124HV12.12...
LWF-1	100×200	H	V 16	97	964	3.034	20,4	4.119.00.100200.124HV12.16...
LWF-1	100×200	H	V 20	96	1.087	3.218	21,7	4.119.00.100200.124HV12.20...
LWF-1	100×200	H	V 25	94	1.232	3.355	23,3	4.119.00.100200.124HV12.25...

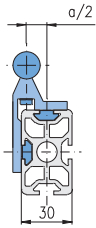

Bez.	Basisprofil Maße	Welle			Trägheitsm.			G kg/m	Bestell-Nr.
		L1	L2	Ø	a/2	lx	ly		
LWF-1	30×50	V	V	12	11	51	13	4,1	4.119.00.030050.44W12.12...
LWF-1	30×50	V	V	16	12	69	14	4,7	4.119.00.030050.44W12.16...

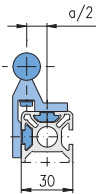

Bez.	Basisprofil Maße	Welle			Trägheitsm.			G kg/m	Bestell-Nr.
		L1	L2	Ø	a/2	lx	ly		
LWF-1	30×60	V	V	12	11	68	13	4,2	4.119.00.030060.64W12.12...
LWF-1	30×60	V	V	16	12	87	14	4,8	4.119.00.030060.64W12.16...

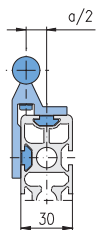

Bez.	Basisprofil Maße	Welle			Trägheitsm.			G kg/m	Bestell-Nr.
		L1	L2	Ø	a/2	lx	ly		
LWF-1	30×100	V	V	12	11	220	19	5,5	4.119.00.030100.84W12.12...
LWF-1	30×100	V	V	16	12	260	20	6,1	4.119.00.030100.84W12.16...

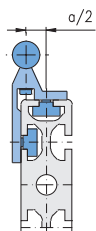

Bez.	Basisprofil Maße	Welle			Trägheitsm.			G kg/m	Bestell-Nr.
		L1	L2	Ø	a/2	lx	ly		
LWF-1	30×150	V	V	12	11	733	33	10,0	4.119.00.030150.84W12.12...
LWF-1	30×150	V	V	16	12	819	34	10,6	4.119.00.030150.84W12.16...

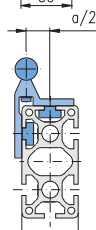

Bez.	Basisprofil Maße	Welle			Trägheitsm.			G kg/m	Bestell-Nr.
		L1	L2	Ø	a/2	lx	ly		
LWF-1	40×80	V	V	12	16	160	36	6,0	4.119.00.040080.65W12.12...
LWF-1	40×80	V	V	16	17	193	38	6,7	4.119.00.040080.65W12.16...
LWF-1	40×80	V	V	20	16	252	42	8,0	4.119.00.040080.65W12.20...
LWF-1	40×80	V	V	25	14	320	44	9,6	4.119.00.040080.65W12.25...

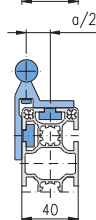

Bez.	Basisprofil Maße	Welle			Trägheitsm.			G kg/m	Bestell-Nr.
		L1	L2	Ø	a/2	lx	ly		
LWF-1	40×120 L	V	V	12	16	351	39	5,9	4.119.00.040120.84LW12.12...
LWF-1	40×120 L	V	V	16	17	400	41	6,6	4.119.00.040120.84LW12.16...
LWF-1	40×120 L	V	V	20	16	491	45	7,9	4.119.00.040120.84LW12.20...
LWF-1	40×120 L	V	V	25	14	589	46	9,5	4.119.00.040120.84LW12.25...

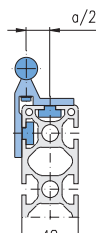

Bez.	Basisprofil Maße	Welle			Trägheitsm.			G kg/m	Bestell-Nr.
		L1	L2	Ø	a/2	lx	ly		
LWF-1	40×160 L	V	V	12	16	764	50	7,8	4.119.00.040160.104LW12.12...
LWF-1	40×160 L	V	V	16	17	846	52	8,5	4.119.00.040160.104LW12.16...
LWF-1	40×160 L	V	V	20	16	1.007	57	9,8	4.119.00.040160.104LW12.20...
LWF-1	40×160 L	V	V	25	14	1.174	58	11,4	4.119.00.040160.104LW12.25...

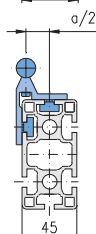

Bez.	Basisprofil Maße	Welle			Trägheitsm.			G kg/m	Bestell-Nr.
		L1	L2	Ø	a/2	lx	ly		
LWF-1	45×90	V	V	12	18,5	226	50	6,6	4.119.00.045090.64W12.12...
LWF-1	45×90	V	V	16	18,5	268	53	7,3	4.119.00.045090.64W12.16...
LWF-1	45×90	V	V	20	18,5	337	58	8,6	4.119.00.045090.64W12.20...
LWF-1	45×90	V	V	25	16,5	420	60	10,2	4.119.00.045090.64W12.25...

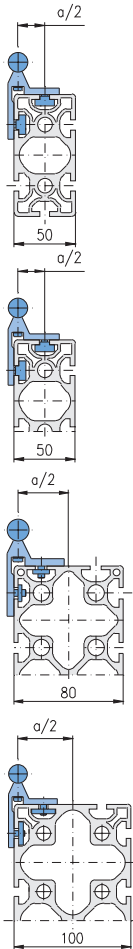

Bez.	Basisprofil Maße	Welle L1 L2 Ø	a/2	Trägheitsm. G		kg/m	Bestell-Nr.
				$I_x$	$I_y$		
LWF-1	50×100	V V 12 21	324	76	8,1	4.119.00.050100.65W12.12...	
LWF-1	50×100	V V 16 22	371	80	8,8	4.119.00.050100.65W12.16...	
LWF-1	50×100	V V 20 21	462	87	10,1	4.119.00.050100.65W12.20...	
LWF-1	50×100	V V 25 19	565	89	11,7	4.119.00.050100.65W12.25...	

Bez.	Basisprofil Maße	Welle L1 L2 Ø	a/2	Trägheitsm. G		kg/m	Bestell-Nr.
				$I_x$	$I_y$		
LWF-1	50×150	V V 12 21	894	103	10,3	4.119.00.050150.85W12.12...	
LWF-1	50×150	V V 16 22	979	107	11,0	4.119.00.050150.85W12.16...	
LWF-1	50×150	V V 20 21	1.151	115	12,3	4.119.00.050150.85W12.20...	
LWF-1	50×150	V V 25 19	1.334	118	13,9	4.119.00.050150.85W12.25...	

Bez.	Basisprofil Maße	Welle L1 L2 Ø	a/2	Trägheitsm. G		kg/m	Bestell-Nr.
				$I_x$	$I_y$		
LWF-1	80×160	V V 12 36	1.227	330	12,7	4.119.00.080160.124W12.12...	
LWF-1	80×160	V V 16 37	1.324	340	13,4	4.119.00.080160.124W12.16...	
LWF-1	80×160	V V 20 36	1.527	362	14,7	4.119.00.080160.124W12.20...	
LWF-1	80×160	V V 25 34	1.743	375	16,3	4.119.00.080160.124W12.25...	

Bez.	Basisprofil Maße	Welle L1 L2 Ø	a/2	Trägheitsm. G		kg/m	Bestell-Nr.
				$I_x$	$I_y$		
LWF-1	100×200	V V 12 46	3.044	858	19,7	4.119.00.100200.124W12.12...	
LWF-1	100×200	V V 16 47	3.193	877	20,4	4.119.00.100200.124W12.16...	
LWF-1	100×200	V V 20 46	3.519	919	21,7	4.119.00.100200.124W12.20...	
LWF-1	100×200	V V 25 44	3.863	946	23,3	4.119.00.100200.124W12.25...	

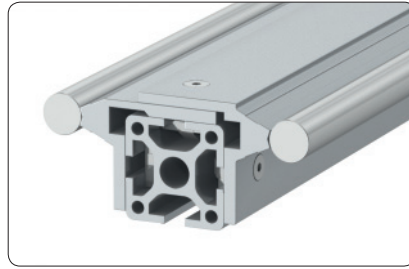
**LWF-2 komplett**  
 (Linear-Wellenführung, zweiseitig)

**Legende**

Bez. = Bezeichnung  
 L1 = Lage des Basisprofils  
 L2 = Lage des Führungsprofils  
 $\emptyset$  = Wellendurchmesser in mm  
 a = Achsabstand in mm  
 Ix, Iy = Trägheitsmoment in cm<sup>4</sup>  
 G = Gewicht in kg/m

**Lage**

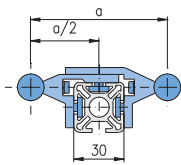
N = neutral  
 H = horizontal  
 V = vertikal



Bez.	Basisprofil Maße	Welle		a	Trägheitsm.		G kg/m	Bestell-Nr.
		L1	L2 $\emptyset$		Ix	Iy		
LWF-2	30x30	N	H 12	74	14	60	5,0	4.119.00.030030.43NH22.12...
LWF-2	30x30	N	H 16	82	16	104	6,5	4.119.00.030030.43NH22.16...

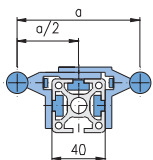

Bez.	Basisprofil Maße	Welle		a	Trägheitsm.		G kg/m	Bestell-Nr.
		L1	L2 $\emptyset$		Ix	Iy		
LWF-2	40x40	N	H 12	84	34	95	6,3	4.119.00.040040.43NH22.12...
LWF-2	40x40	N	H 16	92	37	149	7,8	4.119.00.040040.43NH22.16...
LWF-2	40x40	N	H 20	104	44	263	10,3	4.119.00.040040.43NH22.20...
LWF-2	40x40	N	H 25	112	47	421	13,5	4.119.00.040040.43NH22.25...

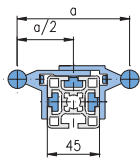

Bez.	Basisprofil Maße	Welle		a	Trägheitsm.		G kg/m	Bestell-Nr.
		L1	L2 $\emptyset$		Ix	Iy		
LWF-2	45x45	N	H 12	89	43	113	6,6	4.119.00.045045.43NH22.12...
LWF-2	45x45	N	H 16	97	47	173	8,1	4.119.00.045045.43NH22.16...
LWF-2	45x45	N	H 20	109	54	299	10,6	4.119.00.045045.43NH22.20...
LWF-2	45x45	N	H 25	117	56	470	13,8	4.119.00.045045.43NH22.25...

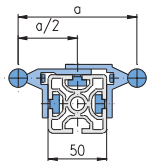

Bez.	Basisprofil Maße	Welle		a	Trägheitsm.		G kg/m	Bestell-Nr.
		L1	L2 $\emptyset$		Ix	Iy		
LWF-2	50x50	N	H 12	94	60	138	7,4	4.119.00.050050.43NH22.12...
LWF-2	50x50	N	H 16	102	65	203	8,9	4.119.00.050050.43NH22.16...
LWF-2	50x50	N	H 20	114	74	342	11,4	4.119.00.050050.43NH22.20...
LWF-2	50x50	N	H 25	122	77	526	14,6	4.119.00.050050.43NH22.25...

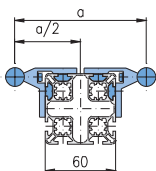

Bez.	Basisprofil Maße	Welle		a	Trägheitsm.		G kg/m	Bestell-Nr.
		L1	L2 $\emptyset$		Ix	Iy		
LWF-2	60x60 L	N	H 12	104	76	182	6,7	4.119.00.060060.83LNH22.12...
LWF-2	60x60 L	N	H 16	112	80	258	8,1	4.119.00.060060.83LNH22.16...

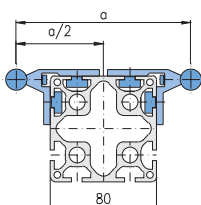

Bez.	Basisprofil Maße	Welle		a	Trägheitsm.		G kg/m	Bestell-Nr.
		L1	L2 $\emptyset$		Ix	Iy		
LWF-2	80x80	N	H 12	124	246	377	10,3	4.119.00.080080.83NH22.12...
LWF-2	80x80	N	H 16	132	253	475	11,7	4.119.00.080080.83NH22.16...
LWF-2	80x80	N	H 20	144	283	703	14,2	4.119.00.080080.83NH22.20...
LWF-2	80x80	N	H 25	152	293	984	17,4	4.119.00.080080.83NH22.25...

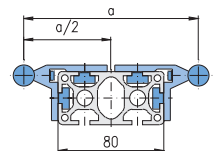
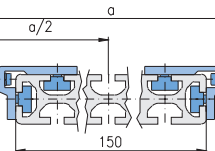
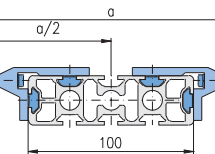
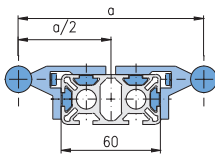
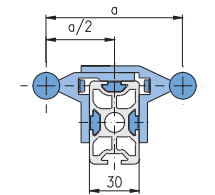
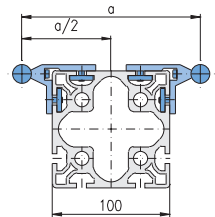
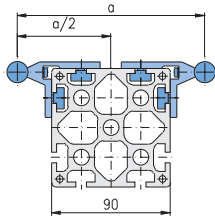
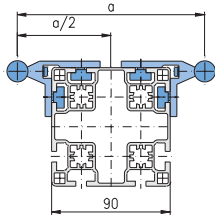

Bez.	Basisprofil Maße	Welle L1 L2 Ø	a	Trägheitsm. G		kg/m	Bestell-Nr.
				lx	ly		
LWF-2	90×90 L N	H 12	134	294	455	9,7	4.119.00.090090.83LNH22.12...
LWF-2	90×90 L N	H 16	142	309	585	11,1	4.119.00.090090.83LNH22.16...
LWF-2	90×90 L N	H 20	154	335	829	17,8	4.119.00.090090.83LNH22.20...
LWF-2	90×90 L N	H 25	162	346	1.148	16,8	4.119.00.090090.83LNH22.25...

Bez.	Basisprofil Maße	Welle L1 L2 Ø	a	Trägheitsm. G		kg/m	Bestell-Nr.
				lx	ly		
LWF-2	90×90 N	H 12	134	408	547	13,9	4.119.00.090090.83NH22.12...
LWF-2	90×90 N	H 16	142	430	677	15,3	4.119.00.090090.83NH22.16...
LWF-2	90×90 N	H 20	154	468	921	17,8	4.119.00.090090.83NH22.20...
LWF-2	90×90 N	H 25	162	488	1.240	21,0	4.119.00.090090.83NH22.25...

Bez.	Basisprofil Maße	Welle L1 L2 Ø	a	Trägheitsm. G		kg/m	Bestell-Nr.
				lx	ly		
LWF-2	100×100 N	H 12	144	558	717	14,1	4.119.00.100100.83NH22.12...
LWF-2	100×100 N	H 16	152	583	850	15,5	4.119.00.100100.83NH22.16...
LWF-2	100×100 N	H 20	164	635	1.143	18,0	4.119.00.100100.83NH22.20...
LWF-2	100×100 N	H 25	172	661	1.501	21,2	4.119.00.100100.83NH22.25...

Bez.	Basisprofil Maße	Welle L1 L2 Ø	a	Trägheitsm. G		kg/m	Bestell-Nr.
				lx	ly		
LWF-2	30×50 H	H 12	94	19	120	6,0	4.119.00.030050.44HH22.12...
LWF-2	30×50 H	H 16	102	21	186	7,5	4.119.00.030050.44HH22.16...

Bez.	Basisprofil Maße	Welle L1 L2 Ø	a	Trägheitsm. G		kg/m	Bestell-Nr.
				lx	ly		
LWF-2	30×60 H	H 12	104	17	158	5,9	4.119.00.030060.64HH22.12...
LWF-2	30×60 H	H 16	112	18	235	7,3	4.119.00.030060.64HH22.16...

Bez.	Basisprofil Maße	Welle L1 L2 Ø	a	Trägheitsm. G		kg/m	Bestell-Nr.
				lx	ly		
LWF-2	30×100 H	H 12	144	24	421	7,5	4.119.00.030100.84HH22.12...
LWF-2	30×100 H	H 16	152	26	554	8,9	4.119.00.030100.84HH22.16...

Bez.	Basisprofil Maße	Welle L1 L2 Ø	a	Trägheitsm. G		kg/m	Bestell-Nr.
				lx	ly		
LWF-2	30×150 H	H 12	194	40	1.115	12,0	4.119.00.030150.84HH22.12...
LWF-2	30×150 H	H 16	202	42	1.341	13,4	4.119.00.030150.84HH22.16...

Bez.	Basisprofil Maße	Welle L1 L2 Ø	a	Trägheitsm. G		kg/m	Bestell-Nr.
				lx	ly		
LWF-2	40×80 H	H 12	124	47	308	8,2	4.119.00.040080.65HH22.12...
LWF-2	40×80 H	H 16	132	49	420	9,6	4.119.00.040080.65HH22.16...
LWF-2	40×80 H	H 20	144	56	634	12,1	4.119.00.040080.65HH22.20...
LWF-2	40×80 H	H 25	152	58	915	15,3	4.119.00.040080.65HH22.25...

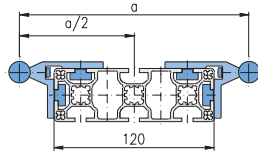

Bez.	Basisprofil Maße	Welle L1 L2 Ø	a	Trägheitsm. G			Bestell-Nr.
				lx	ly	kg/m	
LWF-2	40×120 L H	H 12 164	49	659	8,1	4.119.00.040120.84LHH22.12...	
LWF-2	40×120 L H	H 16 172	52	826	9,5	4.119.00.040120.84LHH22.16...	
LWF-2	40×120 L H	H 20 184	59	1.199	12,0	4.119.00.040120.84LHH22.20...	
LWF-2	40×120 L H	H 25 192	61	1.643	15,2	4.119.00.040120.84LHH22.25...	

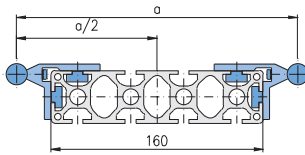

Bez.	Basisprofil Maße	Welle L1 L2 Ø	a	Trägheitsm. G			Bestell-Nr.
				lx	ly	kg/m	
LWF-2	40×160 L H	H 12 204	62	1.263	10,0	4.119.00.040160.104LHH22.12...	
LWF-2	40×160 L H	H 16 212	65	1.510	11,4	4.119.00.040160.104LHH22.16...	
LWF-2	40×160 L H	H 20 224	73	2.070	13,9	4.119.00.040160.104LHH22.20...	
LWF-2	40×160 L H	H 25 232	75	2.716	17,1	4.119.00.040160.104LHH22.25...	

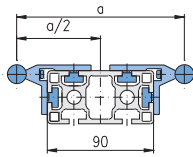

Bez.	Basisprofil Maße	Welle L1 L2 Ø	a	Trägheitsm. G			Bestell-Nr.
				lx	ly	kg/m	
LWF-2	45×90 H	H 12 134	63	403	8,8	4.119.00.045090.64HH22.12...	
LWF-2	45×90 H	H 16 142	67	532	10,2	4.119.00.045090.64HH22.16...	
LWF-2	45×90 H	H 20 154	75	777	12,7	4.119.00.045090.64HH22.20...	
LWF-2	45×90 H	H 25 162	77	1.095	15,9	4.119.00.045090.64HH22.25...	

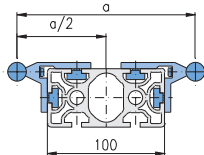

Bez.	Basisprofil Maße	Welle L1 L2 Ø	a	Trägheitsm. G			Bestell-Nr.
				lx	ly	kg/m	
LWF-2	50×100 H	H 12 144	93	530	10,3	4.119.00.050100.65HH22.12...	
LWF-2	50×100 H	H 16 152	98	663	11,7	4.119.00.050100.65HH22.16...	
LWF-2	50×100 H	H 20 164	109	956	14,2	4.119.00.050100.65HH22.20...	
LWF-2	50×100 H	H 25 172	112	1.314	17,4	4.119.00.050100.65HH22.25...	

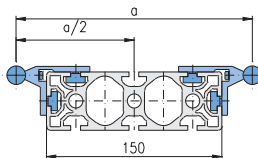

Bez.	Basisprofil Maße	Welle L1 L2 Ø	a	Trägheitsm. G			Bestell-Nr.
				lx	ly	kg/m	
LWF-2	50×150 H	H 12 194	122	1.313	12,5	4.119.00.050150.85HH22.12...	
LWF-2	50×150 H	H 16 202	129	1.539	13,9	4.119.00.050150.85HH22.16...	
LWF-2	50×150 H	H 20 214	141	2.052	16,4	4.119.00.050150.85HH22.20...	
LWF-2	50×150 H	H 25 222	144	2.640	19,6	4.119.00.050150.85HH22.25...	

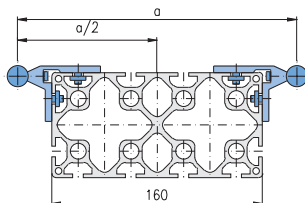

Bez.	Basisprofil Maße	Welle L1 L2 Ø	a	Trägheitsm. G			Bestell-Nr.
				lx	ly	kg/m	
LWF-2	80×160 H	H 12 204	380	1.688	14,9	4.119.00.080160.124HH22.12...	
LWF-2	80×160 H	H 16 212	397	1.936	16,3	4.119.00.080160.124HH22.16...	
LWF-2	80×160 H	H 20 224	430	2.500	18,8	4.119.00.080160.124HH22.20...	
LWF-2	80×160 H	H 25 232	446	3.142	22,0	4.119.00.080160.124HH22.25...	

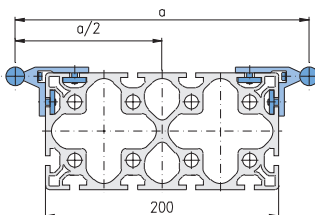

Bez.	Basisprofil Maße	Welle L1 L2 Ø	a	Trägheitsm. G			Bestell-Nr.
				lx	ly	kg/m	
LWF-2	100×200 H	H 12 244	953	3.717	21,9	4.119.00.100200.124HH22.12...	
LWF-2	100×200 H	H 16 252	985	4.060	23,3	4.119.00.100200.124HH22.16...	
LWF-2	100×200 H	H 20 264	1.055	4.858	25,8	4.119.00.100200.124HH22.20...	
LWF-2	100×200 H	H 25 272	1.096	5.733	29,0	4.119.00.100200.124HH22.25...	

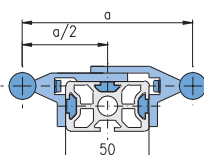

Bez.	Basisprofil Maße	Welle L1 L2 Ø	a	Trägheitsm. G			Bestell-Nr.
				lx	ly	kg/m	
LWF-2	30×50 V	H 12 74	44	66	6,1	4.119.00.030050.44VH22.12...	
LWF-2	30×50 V	H 16 82	48	109	7,6	4.119.00.030050.44VH22.16...	

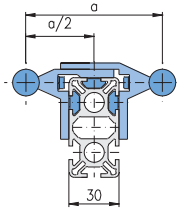

Bez.	Basisprofil Maße	Welle L1 L2 Ø	a	Trägheitsm. G			Bestell-Nr.
				lx	ly	kg/m	
LWF-2	30×60	V H 12	74	62	67	6,2	4.119.00.030060.64VH22.12...
LWF-2	30×60	V H 16	82	67	110	7,7	4.119.00.030060.64VH22.16...

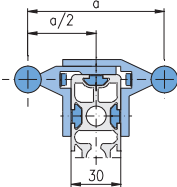

Bez.	Basisprofil Maße	Welle L1 L2 Ø	a	Trägheitsm. G			Bestell-Nr.
				lx	ly	kg/m	
LWF-2	30×100	V H 12	74	229	70	7,5	4.119.00.030100.84VH22.12...
LWF-2	30×100	V H 16	82	247	114	9,0	4.119.00.030100.84VH22.16...

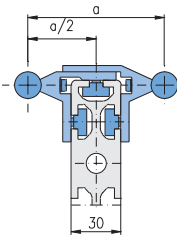

Bez.	Basisprofil Maße	Welle L1 L2 Ø	a	Trägheitsm. G			Bestell-Nr.
				lx	ly	kg/m	
LWF-2	30×150	V H 12	74	837	83	12,0	4.119.00.030150.84VH22.12...
LWF-2	30×150	V H 16	82	903	127	13,5	4.119.00.030150.84VH22.16...

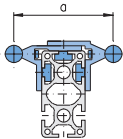

Bez.	Basisprofil Maße	Welle L1 L2 Ø	a	Trägheitsm. G			Bestell-Nr.
				lx	ly	kg/m	
LWF-2	40×80	V H 12	84	160	105	8,1	4.119.00.040080.65VH22.12...
LWF-2	40×80	V H 16	92	172	159	9,6	4.119.00.040080.65VH22.16...
LWF-2	40×80	V H 20	104	191	274	12,1	4.119.00.040080.65VH22.20...
LWF-2	40×80	V H 25	112	196	4.317	15,3	4.119.00.040080.65VH22.25...

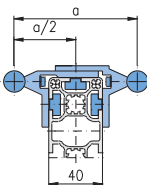

Bez.	Basisprofil Maße	Welle L1 L2 Ø	a	Trägheitsm. G			Bestell-Nr.
				lx	ly	kg/m	
LWF-2	40×120 L V	H 12	84	374	108	8,0	4.119.00.040120.84LVH22.12...
LWF-2	40×120 L V	H 16	92	399	162	9,5	4.119.00.040120.84LVH22.16...
LWF-2	40×120 L V	H 20	104	436	277	12,0	4.119.00.040120.84LVH22.20...
LWF-2	40×120 L V	H 25	112	450	434	15,2	4.119.00.040120.84LVH22.25...

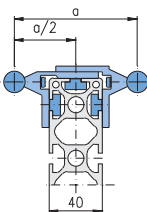

Bez.	Basisprofil Maße	Welle L1 L2 Ø	a	Trägheitsm. G			Bestell-Nr.
				lx	ly	kg/m	
LWF-2	40×160 L V	H 12	84	857	118	9,9	4.119.00.040160.104LVH22.12...
LWF-2	40×160 L V	H 16	92	915	172	11,4	4.119.00.040160.104LVH22.16...
LWF-2	40×160 L V	H 20	104	1.010	287	13,9	4.119.00.040160.104LVH22.20...
LWF-2	40×160 L V	H 25	112	1.056	444	17,1	4.119.00.040160.104LVH22.25...

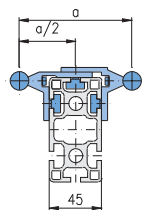

Bez.	Basisprofil Maße	Welle L1 L2 Ø	a	Trägheitsm. G			Bestell-Nr.
				lx	ly	kg/m	
LWF-2	45×90	V H 12	89	234	129	8,7	4.119.00.045090.64VH22.12...
LWF-2	45×90	V H 16	97	251	189	10,2	4.119.00.045090.64VH22.16...
LWF-2	45×90	V H 20	109	277	315	12,7	4.119.00.045090.64VH22.20...
LWF-2	45×90	V H 25	117	286	486	15,9	4.119.00.045090.64VH22.25...

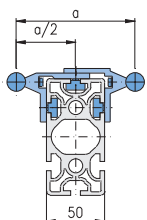

Bez.	Basisprofil Maße	Welle L1 L2 Ø	a	Trägheitsm. G			Bestell-Nr.
				lx	ly	kg/m	
LWF-2	50×100	V H 12	94	344	165	10,2	4.119.00.050100.65VH22.12...
LWF-2	50×100	V H 16	102	369	231	11,7	4.119.00.050100.65VH22.16...
LWF-2	50×100	V H 20	114	409	369	14,2	4.119.00.050100.65VH22.20...
LWF-2	50×100	V H 25	122	424	554	17,4	4.119.00.050100.65VH22.25...



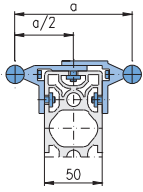

Bez.	Basisprofil Maße	Welle L1 L2 Ø	a	Trägheitsm. G			Bestell-Nr.
				lx	ly	kg/m	
LWF-2	50×150 V	H 12	94	996	191	12,4	4.119.00.050150.65VH22.12...
LWF-2	50×150 V	H 16	102	1.062	257	13,9	4.119.00.050150.85VH22.16...
LWF-2	50×150 V	H 20	114	1.174	395	16,4	4.119.00.050150.85VH22.20...
LWF-2	50×150 V	H 25	122	1.232	580	19,6	4.119.00.050150.85VH22.25...

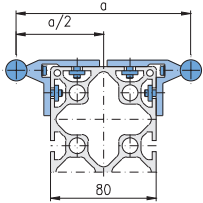

Bez.	Basisprofil Maße	Welle L1 L2 Ø	a	Trägheitsm. G			Bestell-Nr.
				lx	ly	kg/m	
LWF-2	80×160 V	H 12	124	1.376	496	14,9	4.119.00.080160.124VH22.12...
LWF-2	80×160 V	H 16	132	1.441	599	16,3	4.119.00.080160.124VH22.16...
LWF-2	80×160 V	H 20	144	1.580	822	18,8	4.119.00.080160.124VH22.20...
LWF-2	80×160 V	H 25	152	1.666	1.104	22,0	4.119.00.080160.124VH22.25...

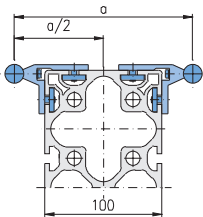

Bez.	Basisprofil Maße	Welle L1 L2 Ø	a	Trägheitsm. G			Bestell-Nr.
				lx	ly	kg/m	
LWF-2	100×200 V	H 12	144	3.370	1.088	21,9	4.119.00.100200.124VH22.12...
LWF-2	100×200 V	H 16	152	3.499	1.221	23,3	4.119.00.100200.124VH22.16...
LWF-2	100×200 V	H 20	164	3.799	1.514	25,8	4.119.00.100200.124VH22.20...
LWF-2	100×200 V	H 25	172	4.007	1.872	29,0	4.119.00.100200.124VH22.25...

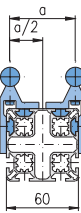

Bez.	Basisprofil Maße	Welle L1 L2 Ø	a	Trägheitsm. G			Bestell-Nr.
				lx	ly	kg/m	
LWF-2	60×60 L N	V 12	52	117	112	6,9	4.119.00.060060.83LNV22.12...
LWF-2	60×60 L N	V 16	54	152	135	8,3	4.119.00.060060.83LNV22.16...

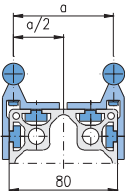

Bez.	Basisprofil Maße	Welle L1 L2 Ø	a	Trägheitsm. G			Bestell-Nr.
				lx	ly	kg/m	
LWF-2	80×80 N	V 12	72	305	295	10,3	4.119.00.080080.83NV22.12...
LWF-2	80×80 N	V 16	74	359	318	11,7	4.119.00.080080.83NV22.16...
LWF-2	80×80 N	V 20	72	476	387	14,2	4.119.00.080080.83NV22.20...
LWF-2	80×80 N	V 25	68	601	431	17,4	4.119.00.080080.83NV22.25...

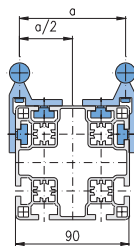

Bez.	Basisprofil Maße	Welle L1 L2 Ø	a	Trägheitsm. G			Bestell-Nr.
				lx	ly	kg/m	
LWF-2	90×90 L N	V 12	82	356	364	9,7	4.119.00.090090.83LNV22.12...
LWF-2	90×90 L N	V 16	84	424	405	11,1	4.119.00.090090.83LNV22.16...
LWF-2	90×90 L N	V 20	82	533	484	13,6	4.119.00.090090.83LNV22.20...
LWF-2	90×90 L N	V 25	78	659	542	16,8	4.119.00.090090.83LNV22.25...

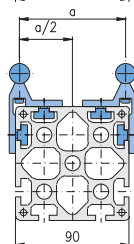

Bez.	Basisprofil Maße	Welle L1 L2 Ø	a	Trägheitsm. G			Bestell-Nr.
				lx	ly	kg/m	
LWF-2	90×90 N	V 12	82	480	456	13,9	4.119.00.090090.83NV22.12...
LWF-2	90×90 N	V 16	84	565	496	15,3	4.119.00.090090.83NV22.16...
LWF-2	90×90 N	V 20	82	708	575	17,8	4.119.00.090090.83NV22.20...
LWF-2	90×90 N	V 25	78	876	634	21,0	4.119.00.090090.83NV22.25...

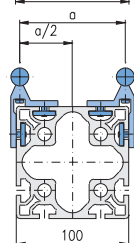

Bez.	Basisprofil Maße	Welle L1 L2 Ø	a	Trägheitsm. G			Bestell-Nr.
				lx	ly	kg/m	
LWF-2	100×100 N	V 12	92	637	617	14,1	4.119.00.100100.83NV22.12...
LWF-2	100×100 N	V 16	94	727	661	15,5	4.119.00.100100.83NV22.16...
LWF-2	100×100 N	V 20	92	897	767	18,0	4.119.00.100100.83NV22.20...
LWF-2	100×100 N	V 25	88	1.087	842	21,2	4.119.00.100100.83NV22.25...

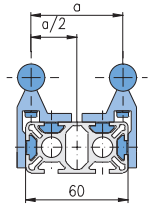

Bez.	Basisprofil Maße	Welle		Trägheitsm.			G kg/m	Bestell-Nr.
		L1	L2 Ø	a	I <sub>x</sub>	I <sub>y</sub>		
LWF-2	30×60	H	V 12	52	40	94	5,9	4.119.00.030060.64HV22.12...
LWF-2	30×60	H	V 16	54	61	109	7,3	4.119.00.030060.64HV22.16...

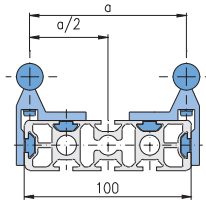

Bez.	Basisprofil Maße	Welle		Trägheitsm.			G kg/m	Bestell-Nr.
		L1	L2 Ø	a	I <sub>x</sub>	I <sub>y</sub>		
LWF-2	30×100	H	V 12	92	50	321	7,5	4.119.00.030100.84HV22.12...
LWF-2	30×100	H	V 16	94	75	37	8,9	4.119.00.030100.84HV22.16...

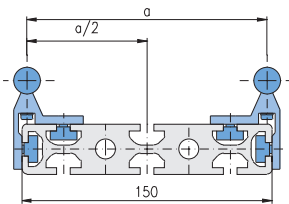

Bez.	Basisprofil Maße	Welle		Trägheitsm.			G kg/m	Bestell-Nr.
		L1	L2 Ø	a	I <sub>x</sub>	I <sub>y</sub>		
LWF-2	30×150	H	V 12	142	71	971	12,0	4.119.00.030150.84HV22.12...
LWF-2	30×150	H	V 16	144	102	1.072	13,4	4.119.00.030150.84HV22.16...

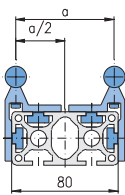

Bez.	Basisprofil Maße	Welle		Trägheitsm.			G kg/m	Bestell-Nr.
		L1	L2 Ø	a	I <sub>x</sub>	I <sub>y</sub>		
LWF-2	40×80	H	V 12	72	80	225	8,2	4.119.00.040080.65HV22.12...
LWF-2	40×80	H	V 16	74	110	253	9,6	4.119.00.040080.65HV22.16...
LWF-2	40×80	H	V 20	72	168	318	12,1	4.119.00.040080.65HV22.20...
LWF-2	40×80	H	V 25	68	234	362	15,3	4.119.00.040080.65HV22.25...

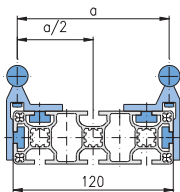

Bez.	Basisprofil Maße	Welle		Trägheitsm.			G kg/m	Bestell-Nr.
		L1	L2 Ø	a	I <sub>x</sub>	I <sub>y</sub>		
LWF-2	40×120 L	H	V 12	112	82	82	8,1	4.119.00.040120.84LHV22.12...
LWF-2	40×120 L	H	V 16	114	113	606	9,5	4.119.00.040120.84LHV22.16...
LWF-2	40×120 L	H	V 20	112	170	762	12,0	4.119.00.040120.84LHV22.20...
LWF-2	40×120 L	H	V 25	108	237	879	15,2	4.119.00.040120.84LHV22.25...

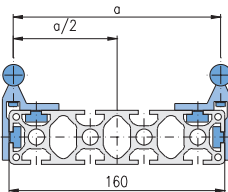

Bez.	Basisprofil Maße	Welle		Trägheitsm.			G kg/m	Bestell-Nr.
		L1	L2 Ø	a	I <sub>x</sub>	I <sub>y</sub>		
LWF-2	40×160 L	H	V 12	152	98	1.111	10,0	4.119.00.040160.104LHV22.12...
LWF-2	40×160 L	H	V 16	154	133	1.225	11,4	4.119.00.040160.104LHV22.16...
LWF-2	40×160 L	H	V 20	152	198	1.515	13,9	4.119.00.040160.104LHV22.20...
LWF-2	40×160 L	H	V 25	148	277	1.742	17,1	4.119.00.040160.104LHV22.25...

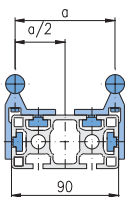

Bez.	Basisprofil Maße	Welle		Trägheitsm.			G kg/m	Bestell-Nr.
		L1	L2 Ø	a	I <sub>x</sub>	I <sub>y</sub>		
LWF-2	45×90	H	V 12	82	100	312	8,8	4.119.00.045090.64HV22.12...
LWF-2	45×90	H	V 16	84	135	347	10,2	4.119.00.045090.64HV22.16...
LWF-2	45×90	H	V 20	82	200	431	12,7	4.119.00.045090.64HV22.20...
LWF-2	45×90	H	V 25	78	276	489	15,9	4.119.00.045090.64HV22.25...

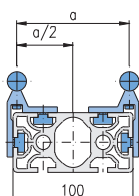

Bez.	Basisprofil Maße	Welle		Trägheitsm.			G kg/m	Bestell-Nr.
		L1	L2 Ø	a	I <sub>x</sub>	I <sub>y</sub>		
LWF-2	50×100	H	V 12	92	135	430	10,3	4.119.00.050100.65HV22.12...
LWF-2	50×100	H	V 16	94	176	474	11,7	4.119.00.050100.65HV22.16...
LWF-2	50×100	H	V 20	92	252	580	14,2	4.119.00.050100.65HV22.20...
LWF-2	50×100	H	V 25	88	341	655	17,4	4.119.00.050100.65HV22.25...

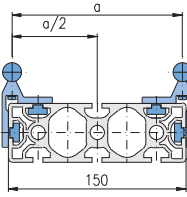

Bez.	Basisprofil Maße	Welle L1 L2 Ø	a	Trägheitsm. G		Bestell-Nr.
				lx	ly	
LWF-2	50×150 H	V 12 142	167	1.170	12,5	4.119.00.050150.85HV22.12...
LWF-2	50×150 H	V 16 144	213	1.270	13,9	4.119.00.050150.85HV22.16...
LWF-2	50×150 H	V 20 142	298	1.523	16,4	4.119.00.050150.85HV22.20...
LWF-2	50×150 H	V 25 138	400	1.719	19,6	4.119.00.050150.85HV22.25...

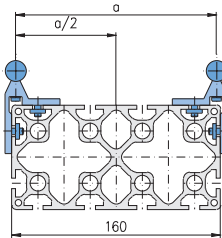

Bez.	Basisprofil Maße	Welle L1 L2 Ø	a	Trägheitsm. G		Bestell-Nr.
				lx	ly	
LWF-2	80×160 H	V 12 152	446	1.536	14,9	4.119.00.080160.124HV22.12...
LWF-2	80×160 H	V 16 154	519	1.651	16,3	4.119.00.080160.124HV22.16...
LWF-2	80×160 H	V 20 152	656	1.941	18,8	4.119.00.080160.124HV22.20...
LWF-2	80×160 H	V 25 148	814	2.168	22,0	4.119.00.080160.124HV22.25...

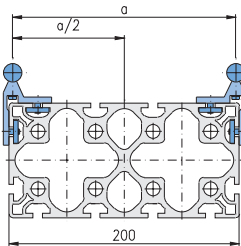

Bez.	Basisprofil Maße	Welle L1 L2 Ø	a	Trägheitsm. G		Bestell-Nr.
				lx	ly	
LWF-2	100×200 H	V 12 192	1.040	3.530	21,9	4.119.00.100200.124HV22.12...
LWF-2	100×200 H	V 16 194	1.147	3.711	23,3	4.119.00.100200.124HV22.16...
LWF-2	100×200 H	V 20 192	1.359	4.176	25,8	4.119.00.100200.124HV22.20...
LWF-2	100×200 H	V 25 188	1.603	4.550	29,0	4.119.00.100200.124HV22.25...

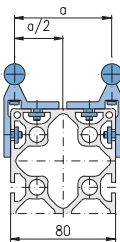

Bez.	Basisprofil Maße	Welle L1 L2 Ø	a	Trägheitsm. G		Bestell-Nr.
				lx	ly	
LWF-2	80×160 V	V 12 72	1.494	414	14,9	4.119.00.080160.124VW22.12...
LWF-2	80×160 V	V 16 74	1.655	442	16,3	4.119.00.080160.124VW22.16...
LWF-2	80×160 V	V 20 72	1.966	507	18,8	4.119.00.080160.124VW22.20...
LWF-2	80×160 V	V 25 68	2.295	550	22,0	4.119.00.080160.124VW22.25...

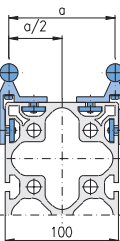

Bez.	Basisprofil Maße	Welle L1 L2 Ø	a	Trägheitsm. G		Bestell-Nr.
				lx	ly	
LWF-2	100×200 V	V 12 92	3.531	988	21,9	4.119.00.100200.124VW22.12...
LWF-2	100×200 V	V 16 94	3.792	1.032	23,3	4.119.00.100200.124VW22.16...
LWF-2	100×200 V	V 20 92	4.340	1.138	25,8	4.119.00.100200.124VW22.20...
LWF-2	100×200 V	V 25 88	4.901	1.213	29,0	4.119.00.100200.124VW22.25...

für Wellen-Ø12

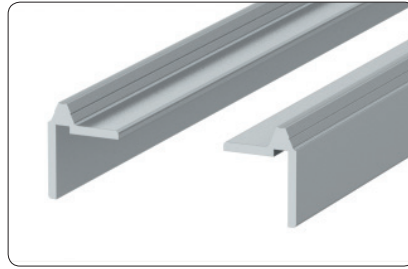

**Technische Daten**

Material: Al Mg Si 0,5 F 25  
 Oberfläche: naturfarben eloxiert  
 Stangenlänge: 6 m  
 Höhen- und Seitentoleranz:  
 • auf Nennmaß: ± 0,2 mm  
 • innerhalb einer Stange: 0,1 mm

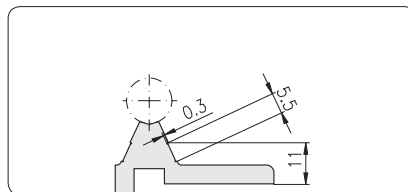
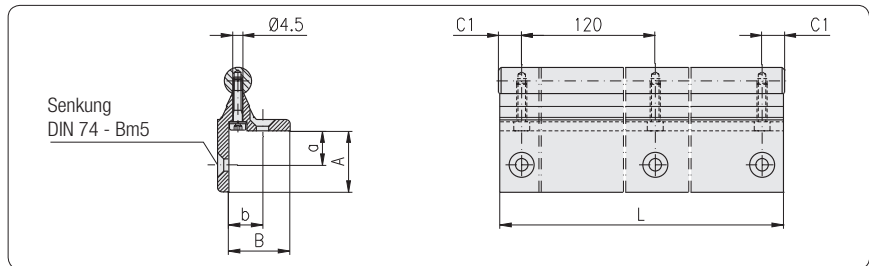

**Berechnung von C1:**

$C1 = 1/2 \cdot (L - n \cdot 120)$

n = max. mögliche Anzahl der Teilungen

Zuschnitt: 4.119.0□.12.□□□□□□□□-02/...

(/... = Länge in mm)

**Typ A**

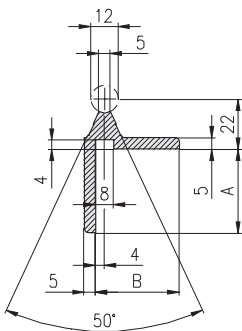

Trägheitsmoment	cm <sup>4</sup>	lx = 8,5	ly = 6,6
Widerstandsmoment	cm <sup>3</sup>	Wx = 2,6	Wy = 2,2
Gewicht (G)	kg/m		

Bezeichnung	A	a	B	b	G	Bestell-Nr.
Wellen-Führungsprofil 12A	37	-	37	-	1,30	4.119.0A.12.37003700.60
Wellen-Führungsprofil 12A	27	15,0	27	15,0	1,03	4.119.0A.12.27152715.60
Wellen-Führungsprofil 12A	27	15,0	37	15,0	1,17	4.119.0A.12.27153715.60
Wellen-Führungsprofil 12A	27	15,0	37	25,0	1,17	4.119.0A.12.27153725.60
Wellen-Führungsprofil 12A	37	20,0	37	20,0	1,30	4.119.0A.12.37203720.60
Wellen-Führungsprofil 12A	37	22,5	37	22,5	1,30	4.119.0A.12.37223722.60
Wellen-Führungsprofil 12A	37	25,0	27	15,0	1,17	4.119.0A.12.37252715.60
Wellen-Führungsprofil 12A	37	25,0	37	25,0	1,30	4.119.0A.12.37253725.60

**Typ B**

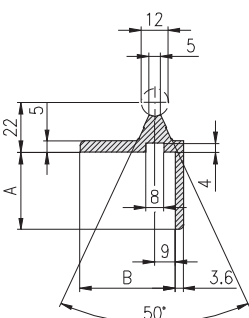

Trägheitsmoment	cm <sup>4</sup>	lx = 5,2	ly = 2,8
Widerstandsmoment	cm <sup>3</sup>	Wx = 1,6	Wy = 1,0
Gewicht (G)	kg/m		

Bezeichnung	A	a	B	b	G	Bestell-Nr.
Wellen-Führungsprofil 12B	34	-	42	-	1,20	4.119.0B.12.34004200.60
Wellen-Führungsprofil 12B	34	15,0	32	20,0	1,07	4.119.0B.12.34153220.60
Wellen-Führungsprofil 12B	34	15,0	42	20,0	1,20	4.119.0B.12.34154220.60
Wellen-Führungsprofil 12B	34	15,0	42	30,0	1,20	4.119.0B.12.34154230.60
Wellen-Führungsprofil 12B	34	20,0	42	25,0	1,20	4.119.0B.12.34204225.60
Wellen-Führungsprofil 12B	34	22,5	42	27,5	1,20	4.119.0B.12.34224227.60
Wellen-Führungsprofil 12B	34	25,0	32	20,0	1,07	4.119.0B.12.34253220.60
Wellen-Führungsprofil 12B	34	25,0	42	30,0	1,20	4.119.0B.12.34254230.60

für Wellen-Ø16

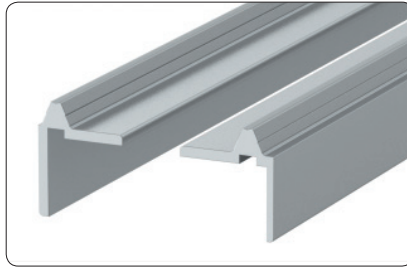

**Technische Daten**

Material: Al Mg Si 0,5 F 25  
 Oberfläche: naturfarben eloxiert  
 Stangenlänge: 6 m  
 Höhen- und Seitentoleranz:  
 • auf Nennmaß: ± 0,2 mm  
 • innerhalb einer Stange: 0,1 mm

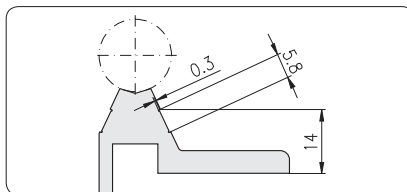
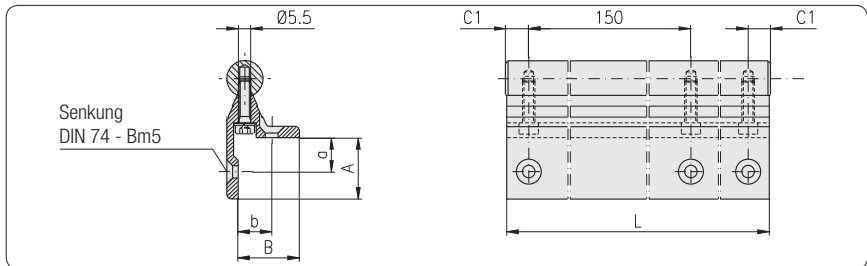

**Berechnung von C1:**

$C1 = 1/2 \cdot (L - n \cdot 150)$

n = max. mögliche Anzahl der Teilungen

Zuschnitt: 4.119.0□.16.□□□□□□□□-02/...

(/... = Länge in mm)

**Typ A**

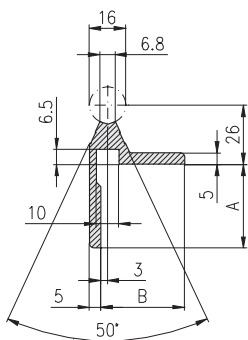

Trägheitsmoment	cm <sup>4</sup>	lx = 10,1	ly = 6,6
Widerstandsmoment	cm <sup>3</sup>	Wx = 3,0	Wy = 2,2
Gewicht (G)	kg/m		

Bezeichnung	A	a	B	b	G	Bestell-Nr.
Wellen-Führungsprofil 16A	37	-	37	-	1,30	4.119.0A.16.37003700.60
Wellen-Führungsprofil 16A	27	15,0	27	15,0	1,03	4.119.0A.16.27152715.60
Wellen-Führungsprofil 16A	27	15,0	37	15,0	1,17	4.119.0A.16.27153715.60
Wellen-Führungsprofil 16A	27	15,0	37	25,0	1,17	4.119.0A.16.27153725.60
Wellen-Führungsprofil 16A	37	15,0	27	15,0	1,17	4.119.0A.16.37152715.60
Wellen-Führungsprofil 16A	37	20,0	37	20,0	1,30	4.119.0A.16.37203720.60
Wellen-Führungsprofil 16A	37	22,5	37	22,5	1,30	4.119.0A.16.37223722.60
Wellen-Führungsprofil 16A	37	25,0	27	15,0	1,17	4.119.0A.16.37252715.60
Wellen-Führungsprofil 16A	37	25,0	37	25,0	1,30	4.119.0A.16.37253725.60

**Typ B**

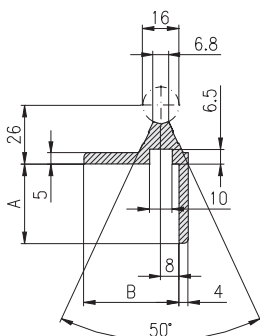

Trägheitsmoment	cm <sup>4</sup>	lx = 7,0	ly = 8,0
Widerstandsmoment	cm <sup>3</sup>	Wx = 2,1	Wy = 2,6
Gewicht (G)	kg/m		

Bezeichnung	A	a	B	b	G	Bestell-Nr.
Wellen-Führungsprofil 16B	35	-	42	-	1,30	4.119.0B.16.35004200.60
Wellen-Führungsprofil 16B	35	15,0	32	20,0	1,17	4.119.0B.16.35153220.60
Wellen-Führungsprofil 16B	35	15,0	42	20,0	1,30	4.119.0B.16.35154220.60
Wellen-Führungsprofil 16B	35	15,0	42	30,0	1,30	4.119.0B.16.35154230.60
Wellen-Führungsprofil 16B	35	20,0	42	25,0	1,30	4.119.0B.16.35204225.60
Wellen-Führungsprofil 16B	35	22,5	42	27,5	1,30	4.119.0B.16.35224227.60
Wellen-Führungsprofil 16B	35	25,0	32	20,0	1,17	4.119.0B.16.35253220.60
Wellen-Führungsprofil 16B	35	25,0	42	30,0	1,30	4.119.0B.16.35254230.60

für Wellen-Ø20

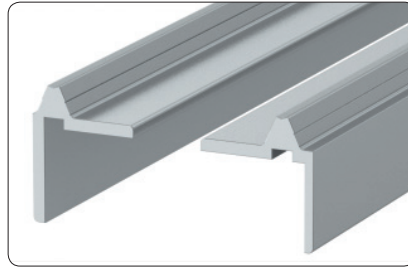

**Technische Daten**

Material: Al Mg Si 0,5 F 25  
 Oberfläche: naturfarben eloxiert  
 Stangenlänge: 6 m  
 Höhen- und Seitentoleranz:  
 • auf Nennmaß: ± 0,2 mm  
 • innerhalb einer Stange: 0,1 mm

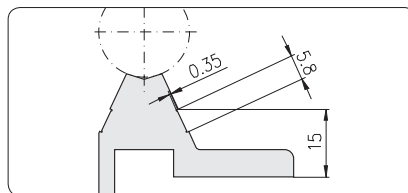
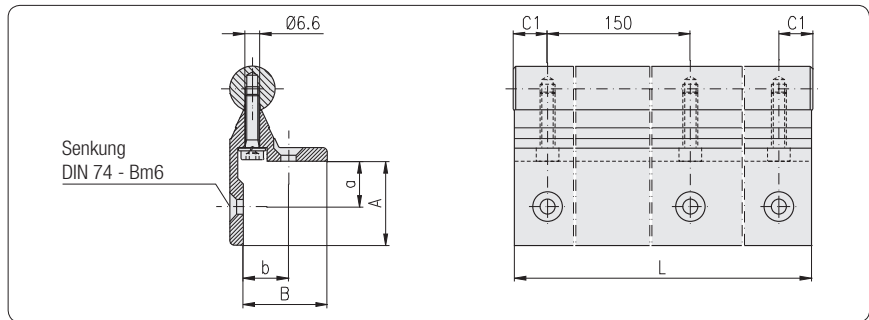

**Berechnung von C1:**

$C1 = 1/2 \cdot (L - n \cdot 150)$

n = max. mögliche Anzahl der Teilungen

Zuschnitt: 4.119.0□.20.□□□□□□□□-02/...

(/... = Länge in mm)

**Typ A**

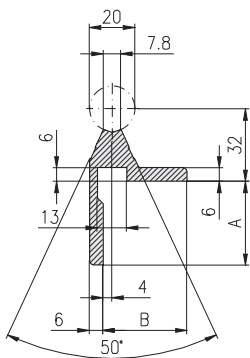

Trägheitsmoment	cm <sup>4</sup>	lx = 14,6	ly = 8,4
Widerstandsmoment	cm <sup>3</sup>	Wx = 4,0	Wy = 2,8
Gewicht (G)	kg/m		

Bezeichnung	A	a	B	b	G	Bestell-Nr.
Wellen-Führungsprofil 20A	37	-	37	-	1,7	4.119.0A.20.37003700.60
Wellen-Führungsprofil 20A	37	20,0	37	20,0	1,7	4.119.0A.20.37203720.60
Wellen-Führungsprofil 20A	37	22,5	37	22,5	1,7	4.119.0A.20.37223722.60
Wellen-Führungsprofil 20A	37	25,0	37	25,0	1,7	4.119.0A.20.37253725.60

**Typ B**

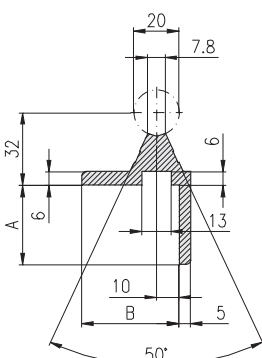

Trägheitsmoment	cm <sup>4</sup>	lx = 10,5	ly = 11,2
Widerstandsmoment	cm <sup>3</sup>	Wx = 2,9	Wy = 3,5
Gewicht (G)	kg/m		

Bezeichnung	A	a	B	b	G	Bestell-Nr.
Wellen-Führungsprofil 20B	35	-	43	-	1,7	4.119.0B.20.35004300.60
Wellen-Führungsprofil 20B	35	20,0	43	26,0	1,7	4.119.0B.20.35204326.60
Wellen-Führungsprofil 20B	35	22,5	43	28,5	1,7	4.119.0B.20.35224328.60
Wellen-Führungsprofil 20B	35	25,0	43	31,0	1,7	4.119.0B.20.35254331.60

für Wellen-Ø25

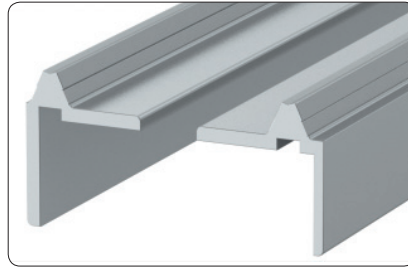

**Technische Daten**

Material: Al Mg Si 0,5 F 25  
 Oberfläche: naturfarben eloxiert  
 Stangenlänge: 6 m  
 Höhen- und Seitentoleranz:  
 • auf Nennmaß: ± 0,2 mm  
 • innerhalb einer Stange: 0,1 mm

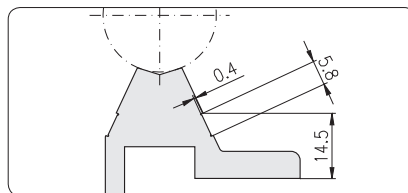
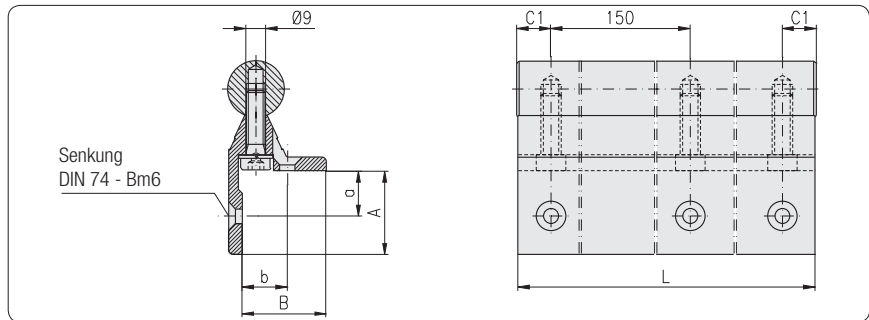

**Berechnung von C1:**

$C1 = 1/2 \cdot (L - n \cdot 150)$   
 n = max. mögliche Anzahl der Teilungen

Zuschnitt: 4.119.0□.25.□□□□□□□□-02/... (/... = Länge in mm)

**Typ A**

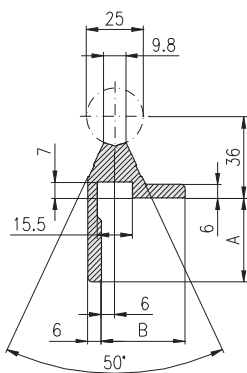

Trägheitsmoment	cm <sup>4</sup>	lx = 16,6	ly = 8,7
Widerstandsmoment	cm <sup>3</sup>	Wx = 4,4	Wy = 2,9
Gewicht (G)	kg/m		

Bezeichnung	A	a	B	b	G	Bestell-Nr.
Wellen-Führungsprofil 25A	37	-	37	-	1,9	4.119.0A.25.37003700.60
Wellen-Führungsprofil 25A	37	20,0	37	20,0	1,9	4.119.0A.25.37203720.60
Wellen-Führungsprofil 25A	37	22,5	37	22,5	1,9	4.119.0A.25.37223722.60
Wellen-Führungsprofil 25A	37	25,0	37	25,0	1,9	4.119.0A.25.37253725.60

**Typ B**

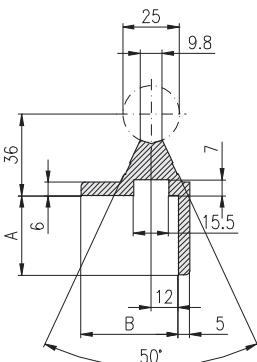

Trägheitsmoment	cm <sup>4</sup>	lx = 11,7	ly = 10,6
Widerstandsmoment	cm <sup>3</sup>	Wx = 3,1	Wy = 3,4
Gewicht (G)	kg/m		

Bezeichnung	A	a	B	b	G	Bestell-Nr.
Wellen-Führungsprofil 25B	35	-	43	-	1,9	4.119.0B.25.35004300.60
Wellen-Führungsprofil 25B	35	20,0	43	26,0	1,9	4.119.0B.25.35204326.60
Wellen-Führungsprofil 25B	35	22,5	43	28,5	1,9	4.119.0B.25.35224328.60
Wellen-Führungsprofil 25B	35	25,0	43	31,0	1,9	4.119.0B.25.35254331.60

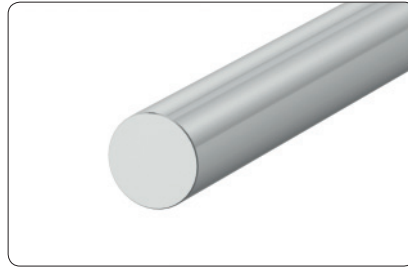
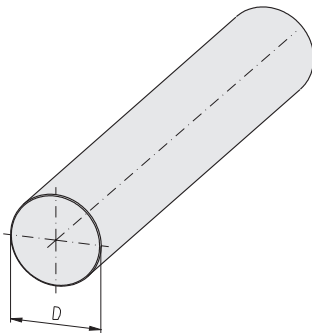
**Wellen**

**Vergütungsstahl**

**Technische Daten**

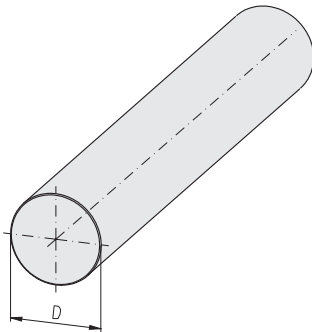
Material: Vergütungsstahl  
 Oberfläche: randschichtgehärtet,  
 geschliffen  
 Oberflächenhärte: 670 + 170HV  
 (59 + 6HRC)  
 Stangenlänge: 6m, Enden ohne Fase  
 Gewicht (G): kg/m

Bezeichnung	D	Rundheit	Parallelität	G	Bestell-Nr.
Welle	12 h6	5 µm	8 µm	0,89	4.119.0W.11.12.60
Welle	16 h6	5 µm	8 µm	1,57	4.119.0W.11.16.60
Welle	20 h6	6 µm	9 µm	2,45	4.119.0W.11.20.60
Welle	25 h6	6 µm	9 µm	3,83	4.119.0W.11.25.60

**Korrosionsbeständiger  
Stahl X46Cr13**

**Technische Daten**

Material: X46Cr13  
 Oberfläche: geschliffen  
 Oberflächenhärte: 560 + 60HV  
 (54 + 3HRC)  
 Stangenlänge: 6m, Enden ohne Fase  
 Gewicht (G): kg/m

Bezeichnung	D	Rundheit	Parallelität	G	Bestell-Nr.
Welle X46Cr13	12 h6	5 µm	8 µm	0,89	4.119.0W.12.12.60
Welle X46Cr13	16 h6	5 µm	8 µm	1,57	4.119.0W.12.16.60
Welle X46Cr13	20 h6	6 µm	9 µm	2,45	4.119.0W.12.20.60
Welle X46Cr13	25 h6	6 µm	9 µm	3,83	4.119.0W.12.25.60

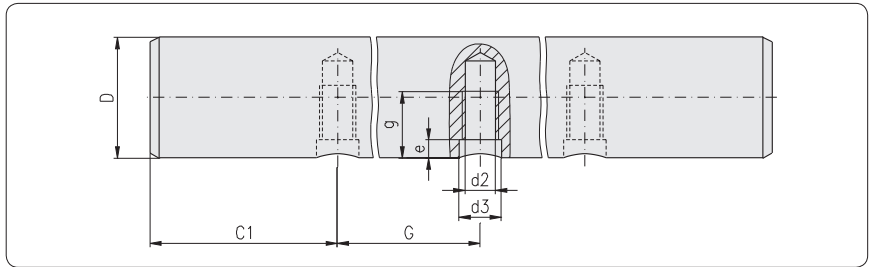
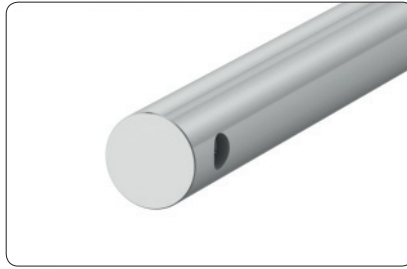

## Wellen



D	d1	d2	d3	g	e	C <sub>1 min</sub> <sup>1)</sup>	G	
12 mm	M5	M4	5	8	2,0	10	120	<sup>1)</sup> Bei Ausführungen mit Axialgewinde ist C1 für die Bohrungstiefe des Axialgewindes anzupassen ↳ 48
16 mm	M6	M5	6	9	2,5	10	150	
20 mm	M8	M6	7	11	3,0	10	150	
25 mm	M10	M8	9	15	3,0	15	150	

### Berechnung von C1:

$$C1 = 1/2 \cdot (L - n \cdot G)$$

n = max. mögliche Anzahl der Teilungen

## Vergütungsstahl

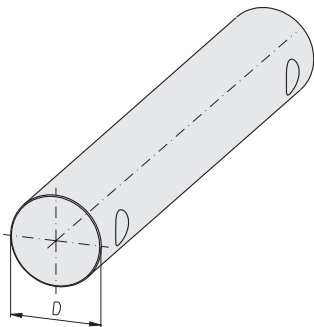

### Technische Daten

Material: Vergütungsstahl  
 Oberfläche: randschichtgehärtet, geschliffen  
 Oberflächenhärte: 670 + 170HV (59 + 6HRC)  
 Stangenlänge: 6m, Enden ohne Fase  
 Gewicht (G): kg/m

Bezeichnung	D	Rundheit	Parallelität	G	Bestell-Nr.
Welle	12 h6	5 µm	8 µm	0,89	4.119.0W.21.12.60
Welle	16 h6	5 µm	8 µm	1,57	4.119.0W.21.16.60
Welle	20 h6	6 µm	9 µm	2,45	4.119.0W.21.20.60
Welle	25 h6	6 µm	9 µm	3,83	4.119.0W.21.25.60

## Korrosionsbeständiger Stahl X46Cr13

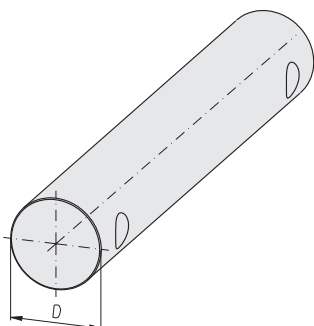



### Technische Daten

Material: X46Cr13  
 Oberfläche: geschliffen  
 Oberflächenhärte: 560 + 60HV (54 + 3HRC)  
 Stangenlänge: 6m, Enden ohne Fase  
 Gewicht (G): kg/m

Bezeichnung	D	Rundheit	Parallelität	G	Bestell-Nr.
Welle X46Cr13	12 h6	5 µm	8 µm	0,89	4.119.0W.22.12.60
Welle X46Cr13	16 h6	5 µm	8 µm	1,57	4.119.0W.22.16.60
Welle X46Cr13	20 h6	6 µm	9 µm	2,45	4.119.0W.22.20.60
Welle X46Cr13	25 h6	6 µm	9 µm	3,83	4.119.0W.22.25.60

Wellen-Bearbeitungen

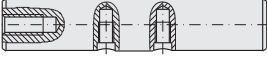
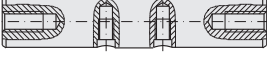
Bezeichnung	
	Wellen-Bearbeitung - 1 Axialgewinde
	Wellen-Bearbeitung - 2 Axialgewinde
	Wellen-Bearbeitung - 1 Axialgewinde u. Radialgewinde
	Wellen-Bearbeitung - 2 Axialgewinde u. Radialgewinde

Maße für Wellen-Bearbeitungen

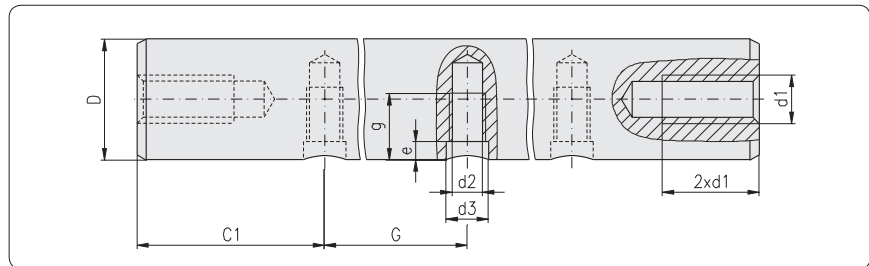

D	d1	d2	d3	g	e	C <sub>1 min</sub> <sup>1)</sup>	G	
12 mm	M5	M4	5	8	2,0	10	120	1) Bei Ausführungen mit Axialgewinde ist C1 für die Bohrungstiefe des Axialgewindes anzupassen
16 mm	M6	M5	6	9	2,5	10	150	
20 mm	M8	M6	7	11	3,0	10	150	
25 mm	M10	M8	9	15	3,0	15	150	

Berechnung von C1:

$$C1 = 1/2 \cdot (L - n \cdot G)$$

n = max. mögliche Anzahl der Teilungen

Längentoleranzen für abgelängte Wellen

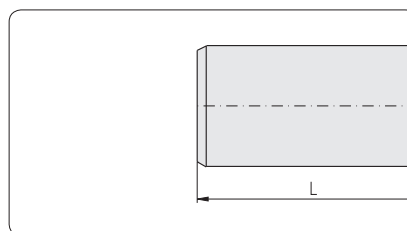

Länge	Toleranz
0 - 400	± 0,5
400 - 1.000	± 0,8
1.000 - 2.000	± 1,2
2.000 - 4.000	± 2,0
4.000 - 6.000	± 3,0

Fase an Wellenenden

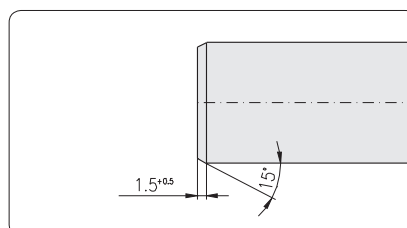

**Bestell-Beispiel**  
für Wellen

Stange 6m	4.119.0W.11.12.60		
Zuschnitte	4.119.0W.11.12-□□□□□□/□□□□		
	4.119.0W.11.12- S □□□□□□/□□□□	links	Schnitt
	4.119.0W.11.12- F □□□□□□/□□□□	links	Fase
	4.119.0W.11.12- A □□□□□□/□□□□	links	Axial-Gewinde
	4.119.0W.11.12- □□□ S □□□□□□/□□□□	rechts	Schnitt
	4.119.0W.11.12- □□□□ F □□□□□□/□□□□	rechts	Fase
	4.119.0W.11.12- □□□□□□ A /□□□□□□	rechts	Axial-Gewinde
	4.119.0W.11.12- □□□□□□□/□□□□□□		Länge in mm

**Impressum**

Technische Änderungen vorbehalten.

Alle Rechte vorbehalten.

Nachdruck, auch auszugsweise, nur mit unserer schriftlichen Genehmigung.

© MayTec Aluminium Systemtechnik GmbH,  
D - 85221 Dachau, 2014

Der Schlüssel ...

zum Erfolg

extrem stabil

wirtschaftlich

funktionell

### Australien

#### MayTec Australia P/L

Unit 8, 175 James Ruse Drive  
Rosehill, NSW 2142

Landesvorwahl: +61  
Telefon: (0)2/98989929  
Telefax: (0)2/96384086  
e-mail: [info@maytec.com.au](mailto:info@maytec.com.au)  
<http://www.maytec.com.au>

### Deutschland

MayTec Aluminium  
Systemtechnik GmbH  
Kopernikusstraße 20  
D-85221 Dachau

Landesvorwahl: +49  
Telefon: (0)8131/3336-0  
Telefax: (0)8131/3336-119  
e-mail: [mail@maytec.de](mailto:mail@maytec.de)  
<http://www.maytec.de>

### USA

#### MayTec Inc.

901 Wesemann Drive  
West Dundee, IL 60118

Landesvorwahl: +1  
Telefon: 847-429-0321  
Telefax: 847-429-0460  
e-mail: [mail@maytecinc.com](mailto:mail@maytecinc.com)  
<http://www.maytecinc.com>

**MayTec**  
Vertriebspartner